

KUOPION YLIOPISTON JULKAISUJA D. LÄÄKETIEDE 423
KUOPIO UNIVERSITY PUBLICATIONS D. MEDICAL SCIENCES 423

HANNELE KARINEN

Genetics and Family Aspects of Coeliac Disease

Doctoral dissertation

To be presented by permission of the Faculty of Medicine of the University of Kuopio
for public examination in Auditorium, Mediteknia building, University of Kuopio,
on Saturday 26th January 2008, at 12 noon

Department of Medicine
Kuopio University Hospital and
Institute of Clinical Medicine, Unit of Internal Medicine,
University of Kuopio



KUOPION YLIOPISTO

KUOPIO 2008

- Distributor:** Kuopio University Library
P.O. Box 1627
FI-70211 KUOPIO
FINLAND
Tel. +358 17 163 430
Fax +358 17 163 410
www.uku.fi/kirjasto/julkaisutoiminta/julkmyyn.html
- Series Editors:** Professor Esko Alhava, M.D., Ph.D.
Institute of Clinical Medicine, Department of Surgery
- Professor Raimo Sulkava, M.D., Ph.D.
School of Public Health and Clinical Nutrition
- Professor Markku Tammi, M.D., Ph.D.
Institute of Biomedicine, Department of Anatomy
- Author's address:** Department of Medicine
Kuopio University Hospital
P.O. Box 1777
FI-70211 KUOPIO
FINLAND
- Supervisors:** Academy Professor Markku Laakso, M.D., Ph.D.
Department of Medicine
Kuopio University Hospital and
Institute of Clinical Medicine, Unit of Internal Medicine
University of Kuopio
- Docent Jussi Pihlajamäki, M.D., Ph.D.
Department of Medicine
Kuopio University Hospital and
Institute of Clinical Medicine, Unit of Internal Medicine
University of Kuopio
- Reviewers:** Docent Katri Kaukinen, M.D., Ph.D.
Medical School
University of Tampere
- Docent Jukka Partanen, Ph.D.
Research and Development
Finnish Red Cross Blood Service
Helsinki
- Opponent:** Docent Pekka Collin, M.D., Ph.D.
Department of Gastroenterology and Aliment Surgery
Tampere University Hospital

ISBN 978-951-27-0943-4

ISBN 978-951-27-1040-9 (PDF)

ISSN 1235-0303

Kopijyvä
Kuopio 2008
Finland

Karinen, Hannele. Genetics and family aspects of coeliac disease. Kuopio University Publications D. Medical Sciences 423. 2008. 110 p.
ISBN 978-951-27-0943-4
ISBN 978-951-27-1040-9 (PDF)
ISSN 1235-0303

ABSTRACT

Background: Coeliac disease (CD) is a common, genetically transmitted, immune-mediated disease characterized by a mucosal lesion in the small intestine. The mucosal lesion is caused by dietary gluten-related proteins and leads to heterogenous symptoms and complications.

Aims: This study was carried out to evaluate the genetic background of CD. In addition, genotype-phenotype correlations and different screening methods for CD in families were investigated with special interest on initial HLA genotyping.

Subjects and methods: The study is based on 54 Finnish families with at least two siblings with CD (54 probands, 467 first-degree relatives). First-degree relatives were examined with duodenal and skin biopsies, serology, nutritional laboratory measures, symptoms, and HLA allele genotyping. A genome-wide scan for susceptibility genes for CD was carried out.

Results: The prevalence of CD was over 20% in our families. In the genome-wide scan two chromosomal regions had a significant association with CD (6p and 2q23-32), and one region showed suggestive association (10p). In addition, an association of the *CTLA-4* gene (located on 2q23-32) with CD was found. The linkage peak at 6p was explained with the known association of CD with the HLA genes. In genotype-phenotype studies, a significant gene dose effect of the HLA *DQB1*0201* allele on the severity of CD was found. The HLA genotyping of the *DQA1*0501*, *DQB1*0201*, and *DRB1*04* alleles proved to be useful in excluding about 20% of the non-affected first-degree relatives from further CD screenings. The relatives carrying any of the forementioned alleles should be further screened for CD despite their gastrointestinal symptoms, which were mild or totally lacking in 76% of CD patients diagnosed in our study. Endomysial antibody screening alone would have missed 17% of the relatives having CD. Antigliadin antibodies were more sensitive, but nonspecific for the diagnosis of CD.

Conclusion: The genetic background of CD remains still partly unknown and needs further studies. The *HLA DQB1*0201* allele contributes to the phenotype of CD. The determination of HLA alleles can be used to exclude a part of relatives from further CD screenings. The rest of the relatives should be screened for CD independently of their symptoms.

National Library of Medicine Classification: QU 470, QW 573, QZ 50, WD 175, WR 200

Medical Subject Headings: Adult; Alleles; Antigens, CD; Antigens, Differentiation/genetics; Biopsy; Celiac Disease/complications; Celiac Disease/diagnosis; Celiac Disease/epidemiology; Celiac Disease/genetics; Dermatitis Herpetiformis; Family; Finland/epidemiology; Genetic Predisposition to Disease; Genetic Screening; Genome; Genotype; HLA Antigens; HLA-DQ Antigens/genetics; HLA-DR Antigens/genetics, Human; Intestine, Small; Linkage (Genetics); Phenotype; Serologic Tests; Siblings



To Ville and Tommi



ACKNOWLEDGEMENTS

This study was carried out at the Department of Medicine, University Hospital of Kuopio, and in the Clinical Research Unit, University of Kuopio in 1996-2007. It is a part of a programme studying the genetics of complex diseases led by Academy Professor Markku Laakso, M.D., Department of Medicine, University of Kuopio.

I wish to express my deepest gratitude to my principal supervisor Academy Professor Markku Laakso, who proposed the topic of this thesis to me and introduced me to the world of scientific research. It has been a privilege to work under his expert, intelligent and enthusiastic guidance. His endless support during all phases of my thesis meant a lot to me.

I wish to owe my sincere gratitude to my supervisor Docent Jussi Pihlajamäki, M.D., for his patience and support during this study. His tireless encouragement was crucial for me especially during some frustrating periods in the preparation of this thesis. He was always able to arrange time for appointments and discussions, even during the last 2.5 years, when he has been working in Joslin Diabetes Center at Harvard Medical School in Boston, USA.

I am grateful to the official reviewers of this thesis, Docent Katri Kaukinen, M.D., and Docent Jukka Partanen, for their criticism and valuable suggestions for the improvement of this thesis. Inspiring discussions with both of the reviewers gave me new views on the topic.

I owe my special thanks to Esko Janatuinen, M.D., and Professor Maija Horsmanheimo, M.D., for helping me to gather the families affected with coeliac disease and dermatitis herpetiformis by giving the names of the index patients to me. I also warmly thank Esko Janatuinen for help during the early phases of this study.

I am very thankful to Docent Risto Julkunen, M.D., the former Head of the Unit of Gastroenterology, Kuopio University Hospital, and Docent Markku Heikkinen, M.D., for their guidance in the field of clinical gastroenterology, as well as in the scientific world.

I warmly thank Professor Veli-Matti Kosma, M.D., and Docent Anita Naukkarinen for conducting all the histological examinations done for this thesis.

I am deeply grateful to Päivi Kärkkäinen, M.Sc., in the Clinical Research Unit, Kuopio University for performing the HLA genotyping in this study. Also, Leena Uschanoff, R.N., and the other staff of the Clinical Research Unit are thanked for their collaboration.

I wish to express my sincere gratitude to Professor Eric Lander, John Rioux, Kerry Kocher, Sheila Guschwan McMahon, Mark Daly, and the others in the Broad Institute / Massachusetts Institute of Technology, Cambridge, USA, for their great collaboration in the genome-wide search.

I wish to thank my research nurses Eija Hämäläinen, Eija Pasanen, and Ulla-Maija Tuovinen for help in examining the patients, and Sirpa Jokilinna for great secretarial work. I thank Matti Ristikankare, M.D., PhD, and other gastroenterology colleagues, as well as the other staff of the gastroenterological department for support and many delightful moments at work.

I am grateful to Tuija Nenonen, Tuula Hakkarainen, and Eeva Oittinen for their expert secretarial help especially in the final processing of the manuscript. I also thank Docent David Laaksonen, M.D., for revising the English text of the manuscript.

I also wish to thank my friends and colleagues in the Department of Medicine, Kuopio University Hospital, for collaboration and support during the process of this thesis. In addition, I would like to thank my gastroenterology colleagues around Finland, especially the members of Donnäs, for great support and encouragement.

I warmly wish to thank all my friends for just being my friends and sharing the different parts of life with me both happy and not so happy moments! I especially thank my “sisters” Maarit Mononen and Päivi Maaranen for a long and firm friendship.

In the end, I would like to thank those who I love most. The greatest and warmest thanks go to my wonderful sons, Ville and Tommi, for bringing a lot of fun and the deepest reason to live to my life. I warmly thank my parents, Kaarina and Heimo, for their loving support and encouragement throughout my life. From them I inherited the belief that I am able to reach the goals I set for myself. I thank my brother, Timo, his wife Tarja and their lovely daughters for bringing a lot of happy moments to our life. To my other relatives, I am very grateful for their constant support.

My final thanks go to all the patients with coeliac disease and their family members who participated in this study. I hope that these results will help in further studies to find better tools for the diagnosis and treatment of their disease.

This work was financially supported by grants from Kuopio University Hospital (EVO grant no. 5119), Kuopio University (LIFE grant), Finnish Foundation for Gastroenterological Research, Finnish Coeliac Society, and Finnish Cultural Foundation.

Kuopio, December 2007

Hannele Karinen

ABBREVIATIONS

AGA	Antigliadin antibody
APC	Antigen-presenting cell
ARA	Antireticulin antibody
CD	Coeliac disease
CTLA-4	Cytotoxic T lymphocyte-associated gene -4
DH	Dermatitis herpetiformis
EATL	Enteropathy associated T-cell lymphoma
EGD	Esophago-gastro-duodenoscopy
ELISA	Enzyme-linked immunosorbent assay
EMA	Endomysial antibody
GFD	Gluten free diet
GI	Gastrointestinal
HLA	Human leucocyte antigen
IEL	Intraepithelial lymphocyte
IF	Immunofluorescence
IFN- γ	Interferon- γ
IL	Interleukin
Ig	Immunoglobulin
MIC	Major histocompatibility complex (MHC) class I chain
MIT	Massachusetts Institute of Technology
MLS	Maximum likelihood score
MYO9B	Myosin IXB gene
NKG2D	Natural killer cell activating receptor
NPL	Non-parametric linkage
OR	Odds ratio
PCR	Polymerase chain reaction
SSCP	Single-strand conformation polymorphism
TDT	Transmission disequilibrium test
tTG	Tissue transglutaminase



LIST OF ORIGINAL PUBLICATIONS

This thesis is based on the following original publications, which will be referred to their Roman numerals.

- I Rioux JD, Karinen H, Kocher K, McMahon SG, Kärkkäinen P, Janatuinen E, Heikkinen M, Julkunen R, Pihlajamäki J, Naukkarinen A, Kosma VM, Daly MJ, Lander ES, Laakso M. Genomewide search and association studies in a Finnish celiac disease population: Identification of a novel locus and replication of the HLA and CTLA4 loci. *Am J Med Genet* 2004;130A: 345-50.
- II Karinen H, Kärkkäinen P, Pihlajamäki J, Janatuinen E, Heikkinen M, Julkunen R, Kosma VM, Naukkarinen A, Laakso M. Gene dose effect of the *DQB1*0201* allele contributes to severity of coeliac disease. *Scand J Gastroenterol* 2006;41:191-99.
- III Karinen H, Kärkkäinen P, Pihlajamäki J, Janatuinen E, Heikkinen M, Julkunen R, Kosma VM, Naukkarinen A, Laakso M. HLA genotyping is useful in the evaluation of the risk for coeliac disease in the first-degree relatives of patients with coeliac disease. *Scand J Gastroenterol* 2006;41:1299-304.
- IV Karinen H, Heikkinen M, Julkunen R, Janatuinen E, Kärkkäinen P, Kosma VM, Naukkarinen A, Pihlajamäki J, Laakso M. The combined role of HLA genotyping, serological tests, and symptoms in the screening for coeliac disease among the first-degree relatives. Submitted.



CONTENTS

1.	INTRODUCTION	15
2.	REVIEW OF THE LITERATURE	16
2.1	Definition of coeliac disease	16
2.2	History of coeliac disease	16
2.3	Genetics of coeliac disease	17
2.3.1	Strategies for genetic studies	17
2.3.2	Family and twin studies	20
2.3.3	HLA genes	22
2.3.3.1	Genes encoding the HLA DQ2 and DQ8 molecules	23
2.3.3.2	Gene dose effect of the DQ2 haplotype and the <i>DQB1*0201</i> allele in the HLA region	26
2.3.3.3	Patients with coeliac disease expressing neither the HLA DQ2 nor the HLA DQ8 molecules	27
2.3.4	Other genes	28
2.3.4.1	Genome-wide scans	28
2.3.4.2	Candidate gene regions	32
2.3.4.3	Candidate genes	32
2.3.5	Genetics of dermatitis herpetiformis	36
2.4	Pathogenesis of coeliac disease	36
2.4.1	Environmental factors	36
2.4.1.1	Gluten and related proteins	36
2.4.1.2	Other environmental factors	38
2.4.2	Tissue transglutaminase enzyme	38
2.4.3	Immunological factors and the role of the HLA II genes	38
2.5	Clinical aspects of coeliac disease	41
2.5.1	Clinical features of coeliac disease	41
2.5.2	Clinical features of dermatitis herpetiformis	43
2.5.3	Diagnosis of coeliac disease and dermatitis herpetiformis	44
2.5.3.1	Small bowel biopsy	44
2.5.3.2	Skin biopsy	45
2.5.3.3	Serological testing	46
2.5.3.4	HLA genotyping	47
2.5.3.5	Other tests	47
2.5.4	Screening for coeliac disease	48
2.5.5	Treatment of coeliac disease	49
3.	AIMS OF THE STUDY	50
4.	SUBJECTS AND METHODS	51
4.1	Subjects and study design	51
4.1.1.	Index patients	51
4.1.2	Study protocol	51
4.1.3	Families participating in the genome-wide scan (Study I)	53
4.1.4	Coeliac disease patients participating in the Study II	54
4.1.5	Families participating in the Study III	54
4.1.6	First-degree relatives participating in the Study IV	56

4.2	Methods	56
4.2.1	Esophago-gastro-duodenoscopy	56
4.2.2	Duodenal biopsies	56
4.2.3	Skin biopsy	57
4.2.4	Serology	58
4.2.5	Other laboratory tests	59
4.2.6	Questionnaire for symptoms	59
4.2.7	HLA genotyping	59
4.2.8	Genome-wide scan	62
4.2.9	<i>CTLA-4</i> genotyping	64
4.2.10	Statistical methods	65
4.3	Approval of the Ethics committee	66
5.	RESULTS	67
5.1	Genome-wide scan to identify susceptibility loci or genes for coeliac disease (Study I)	67
5.2	Gene dose effect of the <i>DQA1*0501</i> allele and the <i>DQB1*0201</i> allele on the severity of coeliac disease (Study II)	68
5.3	HLA genotyping in the evaluation of the risk for coeliac disease in the first-degree relatives (Study III)	72
5.4	Combined role of HLA genotyping, serological tests, and symptoms in the screening for coeliac disease among the first-degree relatives (Study IV)	75
6.	DISCUSSION	79
6.1	Subjects and Study design	79
6.2	Methods	80
6.3	Genetics of coeliac disease (Study I)	81
6.4	Role of the HLA alleles <i>DQA1*0501</i> and <i>DQB1*0201</i> in coeliac disease (Studies II and IV)	83
6.5	Screening for coeliac disease in families (Studies II, III and IV)	85
6.6	Concluding remarks	88
7.	SUMMARY	91
8.	REFERENCES	92

ORIGINAL PUBLICATIONS I-IV

1. INTRODUCTION

Coeliac disease (CD) is a common genetically transmitted disease with a prevalence of 1:50-250 in Finnish and other Western populations (Fasano et al. 2003, Mäki et al. 2003, Dubé et al. 2005, Lohi et al. 2007). CD is characterised by a mucosal inflammation and villous atrophy in the small intestine, which leads to malabsorption of nutrients and heterogenous symptoms from both the gastrointestinal (GI) tract and the extraintestinal area. The pathogenesis of CD is partly unclear, although substantial progress in this field has occurred during the recent years. The pathogenesis of CD involves interaction between genetic, environmental, and immunological factors. Gluten-related proteins are required for the development of CD, and a permanent gluten-free diet (GFD) is currently the only treatment available for CD. CD is strongly associated with the human leucocyte antigen (HLA) DQ2 and DQ8 haplotypes, which are observed in over 90% of patients with CD (Louka et al. 2003). Based on twin and family studies, the HLA genes explain less than 50% of the genetic component of CD (Petronzelli et al. 1997, Bevan et al. 1999a). About 5-22% of the first-degree relatives of CD probands develop the disease during their lifespan, but the mode of inheritance of CD is unclear (Dubé et al. 2005).

In this study, our aim was to collect Finnish families with at least two siblings with CD for a genome-wide scan of CD to identify new genes associated with CD. In addition, our aim was to investigate correlations between genotype and phenotype in patients with CD. Moreover, different strategies for the screening of CD in families were compared, and the role of HLA genotyping in the screening was investigated. Identification of the genes for CD help to understand the pathogenesis and heterogeneity of CD, and enable the development of new treatment strategies and diagnostic procedures for CD.

2. REVIEW OF THE LITERATURE

2.1 Definition of coeliac disease

CD is defined as a permanent intolerance for certain dietary cereals in genetically predisposed individuals, causing a small-bowel mucosal lesion with villous atrophy, crypt hyperplasia, and increased level of intraepithelial lymphocytes (IEL). The small-bowel mucosal lesion gradually leads to symptoms related to GI tract and malnutrition. In some patients, however, extra-intestinal symptoms dominate, while in others the disease is clinically silent. Dermatitis herpetiformis (DH) is a skin manifestation of CD. The specific protein in cereals, gluten, causes CD and DH. Both the GI mucosal lesion and DH recover with GFD.

2.2 History of coeliac disease

Cultivation developed about 10 000 years ago. In the beginning, the cultivation was based on non-gluten containing cereals; rice, sorghum, millet, and maize. Wild wheat and barley were cultivated only in a small area in South East Asia, between South Turkey and Iraq (Greco 1997). These early cereals were different from modern hybrids and contained few gluten components. Farming people spread from South East Asia to Europe and reached Northern Europe about 5000-6000 years ago. Gradually, cultivation of wheat, barley, rye, and oats became common in Europe. Grains were selected based on their bread-making qualities: i.e. for their gluten content. Ultimately, gluten constituted about 50% of the protein content of cereals (Greco 1997). In the last few hundred years the amount of gluten in the daily diet has substantially increased (Greco 1997). However, some individuals have not adapted to the changes in diet, probably because of their genetic background and developed CD.

The “classic” clinical picture of CD (severe steatorrhea and failure to thrive) was first described by Dr Samuel Gee in 1888. In the beginning of the 1950s, the dietary wheat and

related cereals were detected to be triggers of CD by a Dutch paediatrician W.K. Dicke (Dicke 1950). Soon after that gluten was recognised to be the toxic agent in CD. At the same time Paulley reported small-bowel mucosal villous atrophy with chronic inflammation as a characteristic finding in CD (Paulley 1954). Development of peroral intestinal biopsy made diagnosis of CD possible (Shiner 1957). In the 1960s the genetic nature of CD (MacDonald et al. 1965), and the association of CD with DH were proved (Marks et al. 1966). Classic CD presents only a minority of all patients, and CD is a much more common disease than previously thought (Collin et al. 1997, Mäki et al. 1997).

2.3 Genetics of coeliac disease

CD develops as a result of an interaction between genetic, environmental, and immunological factors. A strong association with the certain HLA-class I and II molecules was found in 1970's (Falchuck et al. 1972, Stokes et al. 1972, Keuning et al. 1976, Ek et al 1978). In 1989 the association of CD with particular HLA-DQ α/β -alleles was reported (Sollid et al. 1989). However, based on twin studies, the HLA genes alone do not explain the genetic background of CD, indicating that non-HLA genes are also increasing the susceptibility for CD. CD is supposed to be a polygenic, multifactorial (complex) disease, having a non-Mendelian mode of inheritance.

2.3.1 Strategies for genetic studies

Genetic association studies

Case-control approach

Population-based association studies compare allele or genotype frequencies between unrelated patients and independent unaffected controls. In this type of χ^2 -based gene studies, the risk of false positive results is high, because differences in allele or genotype frequencies

can be due to a different ethnic background. Therefore, careful matching of the control group is important. A common ethnic background of the study groups decreases the genetic heterogeneity between the groups. Most HLA-studies for CD in 1970-1990's have been done using this method.

Family-based association studies

In family-based association studies, the matching problems of case-control studies have been avoided by using family-based controls. The most widely used method is the transmission disequilibrium test (TDT), which is a χ^2 -based test for association and linkage comparing the transmissions and non-transmissions of the marker allele from parents to affected offspring (Spielman et al.1996).

Genetic linkage analyses

In linkage analysis methods developed for the identification of predisposing genes in complex diseases, the degree of allele sharing between affected sib-pairs or all affected relative pairs is compared. The observed allele sharing in families is compared with the sharing probability assuming no linkage (Shih et al.2001). If the frequency of an allele is more frequent than expected by chance in affected siblings or relatives, the susceptibility gene is supposed to be situated in that locus. Among most widely used linkage analyses are the maximum likelihood score method (MLS) and the non-parametric linkage method (NPL) (Kruglyak L et al. 1995, Kruglyak et al. 1996)

Genome-wide random search

Genome-wide screening aims to identify chromosomal regions that are linked to the disease investigated. By using this method, it is possible to find novel loci associated with the disease

of interest and avoid the bias of previous hypotheses of the pathogenesis of the disease. The genome is usually first genotyped for 350-450 microsatellites and the most interesting regions are studied further with a denser set of markers. After screening, the standard linkage analysis in families is performed. The rate of false negative results in this type of genetic method is high since the average inter-marker distance is relatively long. For complex diseases, the results of genome-wide screenings have often been contradictory because of confounding factors complicating the studies (Risch 2000). Using single-nucleotide polymorphisms in genome-wide scans it is possible to identify genes for any complex diseases. So far, this method has not been applied in studies of CD.

Candidate gene approach

The candidate gene approach can be used both in the association and linkage studies. The candidate gene selection is based on the knowledge about the pathogenesis of a disease or on the results of genome-wide screenings done for the disease. An advantage of this approach is the possibility to detect positive or negative associations using markers in the vicinity of the gene accounting for a low frequency of recombination. However, the candidate gene approach has limitations if the knowledge of the pathogenesis of a disease is insufficient.

Animal models

After the predisposing candidate genes have been identified, specific animal models (knock-out and transgenic animals) can be used to examine the pathophysiology of a disease. In CD good animal models have not been published (Louka et al. 2003), but in DH a model exists (Marietta et al. 2004).

2.3.2 Family and twin studies

The importance of genetic factors in CD was first proved by MacDonald et al (1965). The prevalence of CD among the first-degree relatives varies between 2 to over 20% (with most ranging between 10-12%) depending on the population and relatives examined, the methods by which the prevalence was estimated, and the diagnostic criteria used (Table 1, Dubé et al. 2005). From 30 to 50% of the affected first-degree relatives of patients with CD are asymptomatic or have only mild symptoms (Ellis 1981).

The high concordance rate (70-90%) between monozygotic twins gives evidence that CD is a heritable disorder, but also that environmental factors play a role in the pathogenesis (Hervonen et al. 2000, Greco et al. 2002, Nistico et al. 2006). In dizygotic twins the concordance rate is only 10-20% (Greco et al. 2002, Nistico et al. 2006), and in siblings who possess the CD-associated HLA-alleles about 25-30% (Mearin et al. 1983). The phenotype of gluten sensitivity can vary (CD and/or DH) between monozygotic twins (Hervonen et al. 2000).

Table 1. The first family studies done in the first-degree relatives of CD patients using duodenal mucosal biopsies as a screening method.

First Author	Nationality	Year	Number of probands with CD	Number of relatives biopsied (% of relatives)	Number of cases diagnosed (% of relatives / % of relatives biopsied)	Screening method	Diagnostic criteria
MacDonald	Northern American	1965	17	62 (47.0)	7 (5.2 / 11.3)	Biopsy	Subtotal or total villous atrophy
Mylotte	Irish	1974	28	114 (58.5)	12 (6.1 / 10.5)	Biopsy	Subtotal or total villous atrophy
Shipman	Australian	1975	32	131 (91.0)	14 (9.7 / 10.7)	Biopsy	Subtotal or total villous atrophy
Stokes	British	1976	115	182 (26.4)	35 (5.1 / 19.2)	Biopsy	Subtotal or total villous atrophy
Stenhammar	Swedish	1982	32	100 (100.0)	2 (2.0 / 2.0)	Biopsy	Subtotal or total villous atrophy
Auricchio	European (Finnish and Spanish)	1988	51	152 (89.4)	15 (8.8 / 9.7)	Biopsy AGA, ARA	Severe partial, subtotal or total villous atrophy
Mäki	Finnish	1991	42	122 (82.4)	13 (8.8 / 10.7)	Biopsy AGA, ARA	Severe partial, subtotal or total villous atrophy

AGA = Antigliadin antibody

ARA = Antireticulin antibody

2.3.3 HLA genes

The HLA gene complex on the short arm of the chromosome 6 is a cluster of more than 200 gene loci (Figure 1). Almost half of the genes encoded in the cluster have an effect on the immune system (Louka et al. 2003). The role of the HLA molecules, which are coded by the HLA class I and II genes, is to bind and present peptide fragments to T cells.

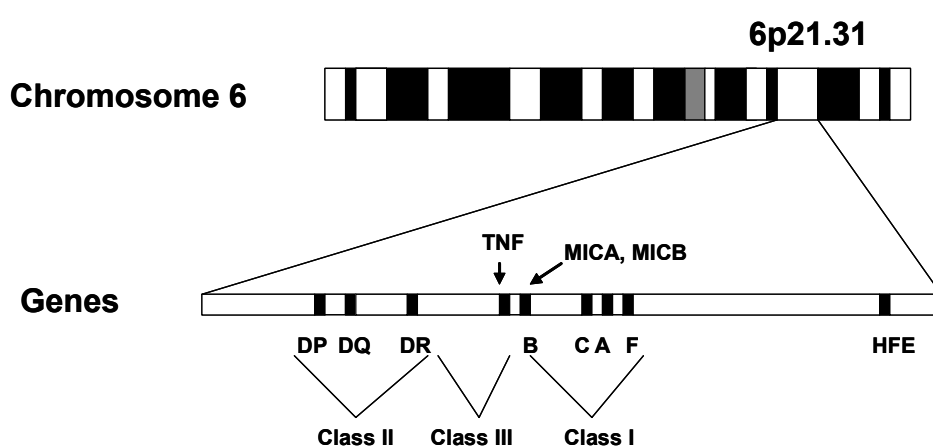

Figure 1. Overview of the extended HLA complex on the chromosome 6 (modified from Louka et al. 2003).

The HLA class II molecules (of the DR, DQ, and DP series) are expressed on the surface of antigen presenting cells (APCs) where they can bind and subsequently present peptides to CD4⁺ T-cells, whereas the HLA class I molecules (of the A, B, and C series) present peptides to CD8⁺ cytotoxic T cells (Sollid et al. 2005b). The HLA complex is the most polymorphic region in the human genome with about 1500 alleles identified (IMGT/HLA at <http://www.ebi.ac.uk/imgt/hla/>). The peptide-binding sites of the polymorphic HLA variants exhibit different form and chemistry and, thus, bind and present different sets of peptides (Sollid et al. 2005b). Because of a strong linkage disequilibrium (non-random association of

linked markers) in the HLA complex, the neighbouring alleles have a tendency to be inherited as a block, and they occur more often together than expected by chance based on their gene frequencies. This makes it difficult to identify genes involved in disease susceptibility. In the 1990's the development of the molecular biological techniques, e.g. polymerase chain reaction (PCR) –based genotyping methods, has made it possible to investigate the association of the HLA region with CD more accurately at the allelic level, instead of serological haplotype determination.

2.3.3.1 Genes encoding the HLA DQ2 and DQ8 molecules

Strong evidence from different populations indicates that genes encoding the HLA-DQ2 and the HLA-DQ8 molecules are the most important predisposing genetic factors in CD (Sollid et al. 1989, Sollid et al. 1990, Tighe et al. 1992, Congia et al. 1992, Louka et al. 2003, Karell et al. 2003). In the European Caucasian populations over 90 % of the CD patients carry the DQ2 haplotype encoded by the *DQA1*0501* or *DQA1*0505* alleles (after this called together as *DQA1*05*), and *DQB1*0201* or *DQB1*0202* alleles (after this called together as *DQB1*02*). Almost all DQ2-negative CD patients carry the DQ8 haplotype, which is encoded by the *DQA1*03* and *DQB1*0302* alleles, and associated with the *DRB1*04* allele (the DR4-DQ8 haplotype) (Spurkland et al. 1992, Polvi et al. 1998a, Karell et al. 2003). Because of the linkage disequilibrium in the HLA region, it has been questioned whether the association of the DQ2 and/or DQ8 haplotype with CD is a true association or only a marker for an association in the HLA region. However, in functional studies gluten has been shown to activate DQ2 and DQ8 restricted T-cells in the small intestine of patients with CD (Lundin et al. 1993, Lundin et al. 1994) and the dose of DQ2 alleles has been shown to contribute to the number of T-cells activated (Vader et al. 2003).

The *DQA1*05* and *DQB1*02* alleles are located on the same chromosome chain in *cis* configuration or in different chromosome chains in *trans* configuration (Figure 2) (Sollid et al. 2005b). When located in the *cis* (most usual case) position, the alleles encoding the DQ2 molecule are the *DQA1*0501* and the *DQB1*0201* alleles, and when located in the *trans* position, the alleles are *DQA1*0505* and *DQB1*0202*. The DQ α chains encoded by the *DQA1*0501* and the *DQA1*0505* alleles differ only by one residue in the leader peptide, and the DQ β chains encoded by the *DQB1*0201* and the *DQB1*0202* alleles differ by one residue in the membrane proximal domain. It is unlikely that these differences have any functional consequence (Sollid et al. 2005b). Instead, the number of the predisposing alleles, especially that of the *DQB1*0201* allele, contributes to disease susceptibility (Table 2).

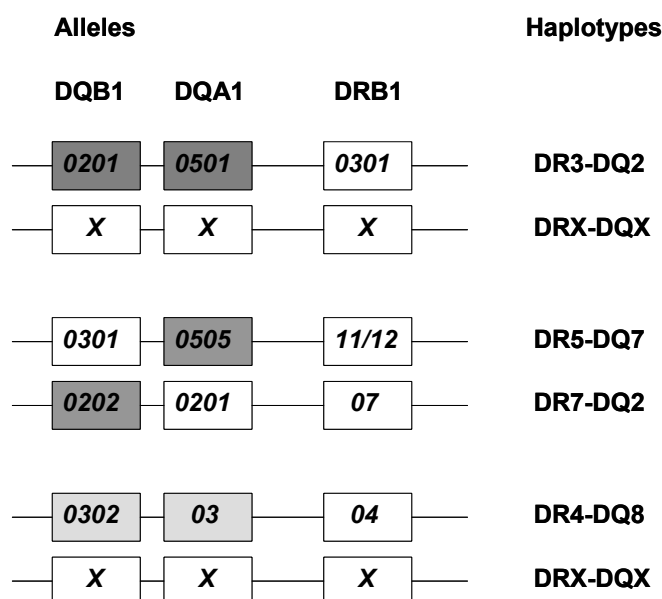

Figure 2. HLA gene association with CD (modified from Sollid et al. 2005b). Risk alleles for CD are marked with grey colour.

Table 2. Studies on the gene dose effect of the DQ2 haplotype and/or DQ2 alleles *DQA1*0501* and *DQB1*0201* on clinical heterogeneity of CD.

First Author	Year	Nationality	N	Age at CD diagnosis ≤ 18 years (%)	Age at CD diagnosis (years)	Genotyping at allele and/or haplotype level	Parameters investigated	Study design	Conclusion
Spurkland	1990	Norwegian	94	100	ND	allele		case-control	<i>DQB1*0201</i> overrepresented
Ploski	1993	Norwegian	94	100	< 3.0 (n=12) ≥ 3.0 (n=82)	allele, haplotype	age, sex	case-control	age†, sex†, <i>DQB1*0201</i> overrepresented
Congia	1994	Sardinian	62	100	mean 3.1 (n=36) mean 5.7 (n=26) < 15.0	haplotype	age, sex, symptoms	case-control	age†, symptoms†, risk†
Meddeb-Garnaoui	1995	French	46	100		allele, haplotype	risk	case-control	risk†
Fernandez-Arquero	1995	Spanish	100	100	mean 1.9	haplotype	risk, sex	case-control	risk†
Polvi	1996	Finnish	49	>70	median 8.0 (n=31) median 36.5 (n=14)	allele, haplotype	age, sex, symptoms	family	no significant association
Ploski	1996	Swedish	129	100	median 1.0 (n=48) median 1.2 (n=81) mean 4.0	allele, haplotype	age, sex, symptoms	case-control	<i>DQB1*0201</i> overrepresented†
Arranz	1997	Spanish	50	100		haplotype	risk	family	no significant association
Greco	1998b	Italian	145	100	approximately < 7.0	allele, haplotype	age, sex, symptoms, growth, co-existing disease	case-control	no significant association
Liu	2002	Finnish	260	mainly adults	median 37.0	allele, haplotype		family	<i>DQB1*0201</i> overrepresented
Zubillaga	2002	Spanish	133	100	mean 3.1 median 1.8	allele, haplotype	age, sex, symptoms, delay in diagnosis, AGA, villous atrophy, co-existing disease, height, weight	case	age†, sex†, symptoms†, delay in diagnosis†
Mustalahti	2002	Finnish	56	mainly adults	median 29.0 (n=28) median 38.0 (n=28)	haplotype	age, symptomatic/silent	family	no significant association

† Significant association with gene dose

AGA=Antigliadin antibody

Although the HLA risk alleles are important, they are not sufficient for the development of CD. In Western countries 20-30% of the population carries the DQ2 alleles associated with CD, and only a minority (~5%) of them develops CD (Liu et al. 2002, Sollid et al. 2005b). Furthermore, only about 25-30 % of siblings of a CD patient who carry the HLA risk alleles, will develop CD (Mearin et al. 1983). The HLA-associated risk has been estimated to account for 36-40% of the genetic component of CD (Petronzelli et al. 1997, Bevan et al. 1999a). By repeating the analysis made by Petronzelli et al. (1997), using a population prevalence of 1:100 instead of 3:1000, the estimate of the HLA effect on the risk of CD is 53% (Sollid et al. 2005b).

2.3.3.2 Gene dose effect of the DQ2 haplotype and the *DQB1*0201* allele in the HLA region

In several studies the risk of CD has been found to be higher in subjects homozygous for the DQ2 haplotype or the *DQB1*0201* allele (Table 2). Conflicting data have been published on the gene dose effect of the number of the DQ2 haplotype or *DQB1*0201* alleles on the age at diagnosis and symptoms of CD. Some studies have suggested a gene dose effect of the DQ2 haplotype on the age at diagnosis (Ploski et al. 1993, Congia et al. 1994, Zubillaga et al. 2002), whereas other studies have failed to demonstrate such an effect (Polvi et al. 1996, Ploski et al. 1996, Greco et al. 1998b, Mustalahti et al. 2002). Similarly, the results of the gene dose effect of the DQ2 haplotype or the *DQB1*0201* allele on symptoms of CD have been controversial (Congia et al. 1994, Polvi et al. 1996, Ploski et al. 1996, Greco et al. 1998b, Zubillaga et al. 2002). Zubillaga et al (2002) did not find an association between the gene dose effect of either the DQ2 haplotype or the *DQB1*0201* allele and the grading of villous atrophy in a paediatric study population. Recently, the HLA DQ2 homozygosity has

been associated with refractory CD (type II with aberrant T-cells) and enteropathy-associated T-cell lymphoma (EATL) (Al-Toma et al. 2006).

Functional studies have given further evidence for the importance of the gene dose effect of the DQ2 alleles. Vader et al. (2003) have shown that gluten presented by the HLA-DQ2 homozygous APCs results in at least 4-fold higher T-cell response compared with gluten presentation by the HLA-DQ2 heterozygous APCs. The 3-dimensional structure analyses of the HLA II molecules indicate that even small differences between the coding alleles can change the peptide binding properties of the HLA molecule (Partanen 1997). Furthermore, as the HLA-DQ2 heterozygotes express two distinct DQ α and DQ β chains, they can form four distinct HLA-DQ-dimers of which only one will be HLA-DQ2. In contrast, all the HLA-DQ dimers in HLA-DQ2 homozygotes will be of the HLA-DQ2 type, which is needed in the pathogenesis of CD (Koning et al. 2005). In addition, Holm et al. (1992) found a dose response effect of the *DQA* and *DQB* genes on the number of intraepithelial $\gamma\delta$ T cells in CD patients and their relatives.

2.3.3.3 Patients with coeliac disease expressing neither the HLA DQ2 nor the HLA DQ8 molecules

The number of CD patients who are not carriers of either the HLA DQ2 (encoded by the *DQA1*05* and *DQB1*02* alleles) or the HLA DQ8 (encoded by the *DQA1*03* and *DQB1*0302* alleles) is low. In the European Genetics Cluster on Celiac disease –study, 61 out of 1008 (6.1%) European coeliac subjects carried neither the DQ2 nor the DQ8 haplotypes (Karell et al. 2003). However, 57 of 61 subjects carried either the *DQB1*02* allele or the *DQA1*05* allele alone. Thus, only 0.4% carried none of the HLA alleles associated with CD.

In another study of Finnish and Spanish patients with CD, 0.7% of patients did not carry any of the HLA risk alleles (Polvi et al. 1998a).

2.3.4 Other genes

The family and twin studies of CD, carried out before 1990's, suggested that there is at least one non-HLA locus for CD. The importance of the non-HLA linked genes has been estimated to be greater than that of the HLA genes (Risch et al. 1987, Petronzelli et al. 1997, Bevan et al. 1999a).

2.3.4.1 Genome-wide scans

To determine the localisation of the genes susceptible for CD, several genome-wide scans have been undertaken during the last decade (Table 3). So far, the only locus constantly replicated is the HLA region, and the chromosomal regions showing evidence for linkage have differed among the studies. Altogether, these studies have identified 20-30 chromosomal regions that could contain susceptibility gene(s). Several regions are believed to be false positives, and some true regions are likely to have been overlooked. Limited sample size and heterogeneity between the populations weaken the probability to find the predisposing genes.

The region, which has been most consistently (but not significantly) linked to CD, lies on chromosome 5 (5q31-33) (Greco et al. 1998a, Naluai et al. 2001, Liu et al. 2002, van Belzen et al. 2003). The 5q region harbours a cytokine gene cluster, which is involved in the T-helper cell subset 2 type of immune response. In a meta-analysis of genome-wide scans from several European populations, this region was significantly associated with CD (Babron et al. 2003). To date, four regions have been indentified as susceptibility loci, ie, *CELIAC1* (HLA-DQ), *CELIAC2* (5q31-33), *CELIAC3* (2q33), and *CELIAC4* (19p13.11) (Sollid et al. 2005b). Only

one non-HLA region, *CELIAC3*, involves a gene which is likely to be associated with CD (cytotoxic T lymphocyte associated gene -4 (*CTLA-4*)) (Table 4). Recently, the myosin IXB gene (*MYO9B*) was identified as the likely susceptibility gene in the *CELIAC4*-region in a Dutch population (Monsuur et al. 2005), but this finding has not been replicated in other studies from different populations (Amundsen et al. 2006, Giordano et al. 2006, Hunt et al. 2006, Nunez et al 2006b, Cirillo et al. 2007, Latiano et al. 2007, van Heel et al. 2007). In addition, a significant association with a gene region 4q23 harbouring the *IL2* and *IL21* genes was found in a recent genomewide association study (van Heel et al. 2007).

Table 3. Genome-wide scans done for the detection of predisposing genes for CD.

First Author	Population	Year	Number of families	Number of CD patients	Significant* linkage	Suggestive* linkage	Almost suggestive* linkage
Zhong	Ireland	1996	15	40	6p23, 6p21.3, 11p11	7q31.3, 22cen	15q26
Greco	Italy	1998a	103	210?	6p21		5qter, 11qter
King	Great Britain	2000	16	47			10q23.1, 16q23.3
Naluai	Sweden and Norway	2001	106	248	6p	11q23-25	2q11-13, Xp11
Liu	Finland	2002	98	256	6p21.3	4p	
Woolley	Finland	2002b	9	23	15q11-q13		
Neuhausen	USA	2002	62	128(+65)	6p		3p, 5p, 10p, 18q
Popat	Northern Europe	2002a	24	88		6p21	19p13.3, 4p14
Van Belzen	Netherlands	2003	82	173	HLA, 19p13.1	6q21-22	
Babron	Europe (pooled)	2003	442	1056	HLA	5q31-33	
Van Belzen	Netherlands	2004b	1	17		HLA, 9p21-13	
Gamer	USA	2007	160	544	6p	7q, 9q	1q, 3q, 6q, 10q
van Heel	Great Britain	2007		788	HLA, 4q27		2q33

*Significant linkage: Lod score ≥ 3.6 (p -value ≤ 0.00002), suggestive linkage: Lod score ≥ 2.2 (p -value ≤ 0.0007) (criteria proposed by Lander and Kruglyak 1995).

Table 4. Studies on the association of the *CTLA-4* gene (and/or *CD28* or *ICOS* genes) with CD.

First author	Nationality	Year	Gene	N	Method	Association
Djilali-Saiah	French	1998	<i>CTLA-4</i>	101 CD 130 contr	case-control	+
Holopainen	Finnish	1999	<i>CD28</i> <i>CTLA-4</i>	250 CD	family	+ suggestive
Clot	Italian and Tunisian	1999	<i>CTLA-4</i>	272 CD 232 fam	family	-
Naluai	Swedish and Norwegian	2000	<i>CTLA-4</i>	107 fam	family	+
Neuhausen	American	2001	<i>CTLA-4</i>	175 CD 62 fam	family	-
Popat	Swedish	2002d	<i>CTLA-4</i>	62 CD		+
Popat	Swedish	2002b	<i>CD28</i>	52 CD		-
Popat	Northern European	2002c	<i>CTLA-4</i> , <i>CD28</i>	311 CD 116 fam	family	+ suggestive
King	British	2002	<i>CTLA-4</i>	166 fam	family	+
Mora	Italian	2003	<i>CTLA-4</i>	199 CD, 144 contr 113 fam	family case-control	+ -
Martin-Pagola	Spanish	2003	<i>CTLA-4</i>	43 CD 41 fam	family	-
King	British	2003	<i>CTLA-4</i>	149 fam	family	-
Van Belzen	Dutch	2004a	<i>CTLA4</i>	215 CD 215 contr	case-control	+ borderline
Amundsen	Swedish and Norwegian	2004	<i>CD28</i> <i>CTLA-4</i> <i>ICOS</i>	325 fam	family	+
Haimila	Finnish	2004	<i>CTLA-4</i> <i>CD28</i> <i>ICOS</i>	106 fam	family	-
Holopainen	European	2004	<i>CTLA-4</i> <i>CD28</i> <i>ICOS</i>	796 fam	family	+
Hunt	British	2005	<i>CTLA-4</i> <i>ICOS</i>	340 CD 973 contr	case-control	+
Brophy	Irish	2006	<i>CTLA-4</i> <i>CD28</i> <i>ICOS</i>	394 CD, 421 contr	case-control	+

Abbreviations: Fam = families, Contr= controls, “+” = positive association, “-” = no association

2.3.4.2 Candidate gene regions

The non-HLA candidate gene regions which were identified in the first genome-wide scan (Zhong et al. 1996) have been further examined in linkage studies of CD families. Houlston et al. (1997) found a weak evidence for 15q26, whereas other investigators failed to find evidence for an association (Brett et al. 1998, Neuhausen et al. 2001, Susi et al. 2001). In the second genome-wide scan, some evidence for an association with the region 5q was reported (Greco et al. 1998a), but in a further study with a new sample of 89 Italian sibpairs, the linkage was not any more suggestive to the 5q region (Greco et al. 2001). However, when the original and new sib pair sets were combined, the linkage to region 5q reached suggestive evidence for an association (MLS 2.92). The same group replicated their findings using a denser marker set in the region 5q (MLS 2.53) (Percopo et al. 2003). In a Finnish study including 102 families, an association with the region 5q was found only for a small subgroup of families having both CD and DH (Holopainen et al. 2001). King et al. (2001) reinvestigated 17 potential gene regions, which they identified in their original whole genome scan, in a larger set of pedigrees, and found a suggestive linkage to the 11p11 region.

2.3.4.3 Candidate genes

Potential candidate genes include genes regulating the immune function and the other stages of CD pathogenesis. Of candidate genes for CD investigated during the recent years (Table 5) only the locus on chromosome 2q33 containing the *CTLA-4*, *CD28*, and *ICOS* genes has given constant association (Table 4). CD28 and CTLA-4 molecules are expressed by T lymphocytes and interact with their ligands B7-1 (CD80) and B7-2 (CD86) during antigenic stimulation of T cells via the T cell receptor. CD 28 provides a co-stimulatory signal to T cell activation, while CTLA-4 provides a negative signal and thus is thought to be an important regulator of autoimmunity (King et al. 2002).

Table 5. Summary of studies on candidate genes for CD.

Chromosome (localisation)	Gene	Function	Association	First Author and Year of Publication
Chromosome 1 1q31-32	<i>IL-10</i>	Inhibitor of monocyte and macrophage activation	+/-	Hahn-Zoric 2003, Barisani 2006 / Cataldo 2003, Lio 2005, Woolley 2005, Nunez 2006a
Chromosome 2 2q33	<i>CTLA-4</i>	T-cell activation	+/-	Details in Table 4
2q33	<i>CD28</i>	T-cell activation	+/-	Details in Table 4
2q33	<i>ICOS</i>	Immune response	+	Details in Table 4
2q37.3	<i>PD-1</i>	Immune response	-	Haimila 2004
2q32.2	<i>STAT-1</i>	Immune response	-	Diosdado 2006
Chromosome 3 3q13.3-21	<i>CD80</i> <i>CD86</i>	T-cell activation	-	Woolley 2002a
Chromosome 4 4q26-27	<i>IL2 / IL-21</i>	Immune response	+	van Heel 2007
Chromosome 5 5q31.1-33.1	<i>IL12B</i>	γ -interferon production	-	Louka 2002b, Seegers 2003
5q31.1-33.1	<i>CD14</i>	Immune response	-	Boniotto 2003
5q31.1	<i>IL4</i>	Immune response	-	Ryan 2005
5q31.1	<i>IL5</i>	Immune response	-	Ryan 2005
5q31.1	<i>IL9</i>	Immune response	-	Ryan 2005
5q31	<i>IL13</i>	Immune response	-	Ryan 2005
5q32-34	<i>IL17B</i>	Immune response	-	Ryan 2005
5q31.3	<i>NR3C1</i>	Immune response	-	Ryan 2005
5q31.1	<i>SLC22A4</i>	Immune response	-	Ryan 2004

Continued	
Chromosome 6	
6p21.3	<i>HLA-DQ2/DQ8</i>
6p21.3	<i>TAP1/TAP2</i>
6p21.3	<i>HSP70-2</i>
6p21.3	<i>TNF</i>
6p21.3	<i>MICA</i>
6p21.3	<i>MICB</i>
6q21-22	<i>PREP</i>
Chromosome 7	
7p14	<i>TCR-γ</i>
7q34	<i>TCR-β</i>
7q11.23	<i>ELN</i>
Chromosome 11	
11q22.3	<i>MMP1 & -3</i>
Chromosome 12	
	<i>IFN-γ</i>
Chromosome 14	
14q11.2	<i>TCR-α</i>
14q11.2	<i>TCR-δ</i>

See the chapter "HLA genes"
Powis 1993

Ramos-Arroyo 2001 / Partanen 1993

McManus 1996, de la Concha 2000, Garrote 2002, Cataldo 2003, Lio 2005, Woolley 2005 / Polvi 1998b, Barisani 2006
Lopez-Vazquez 2002, Rueda 2003, Lopez-Vasquez 2004 / Bilbao 2002, Fernandez 2002, Woolley 2005
Gonzalez 2004, Rodriguez-Rodero 2006
Diosdado 2005

Roschmann 1993, Thurley 1994, Arai 1995, Yiannakou 1999, Neuhausen 2001

Roschmann 1993, Thurley 1994, Yiannakou 1999, Neuhausen 2001

Grillo 2000

Mora 2005 / Louka 2002a

Rueda 2004, Lio 2005 / Wapenaar 2004, Woolley 2005, Barisani 2006

Roschmann 1993, Thurley 1994, Yiannakou 1999, Neuhausen 2001

Roschmann 1993, Thurley 1994, Yiannakou 1999, Neuhausen 2001

Continued				
Chromosome 17				
17q11.2-12	<i>NOS2</i>	Nitric oxide production	-	Rueda 2002
Chromosome 19				
19p13.1	<i>MYO9B</i>	Intestinal barrier	+/-	Monuur 2005 /Amundsen 2006, Giordano 2006, Hunt 2006, Nunez 2006b, Cirillo 2007, Latiano 2007
19q13.4	<i>KIR/LILR</i>	Leucocyte receptors	+/-	Santin 2007 / Moodie 2002
19pter	<i>CYP4F2</i>	Neutrophil activation	+	Curley 2006
19p13.11	<i>CYP4F3</i>			
Chromosome 20				
20q12	<i>tTG</i>	tTG enzyme	-	Aldersley 2000, van Belzen 2001, Popat 2001
Chromosome X				
Xp11.23	<i>FOXP3</i>	Development and function of T regulatory cells	-	Bjornvold 2006

“+” = positive association, “-” = no association

2.3.5 Genetics of dermatitis herpetiformis

DH is associated with the same HLA alleles as CD (Hall et al. 1991, Balas et al. 1997, Spurkland et al. 1997, Karell et al. 2002). CD and DH have been found to cluster in the same families (Marks et al. 1970, Reunala et al. 1976, Hervonen et al. 2002). Differences in the genetic background of CD and DH might explain the phenotype differences between them but thus far, no other genes, except for the HLA alleles, have been found to be associated with DH.

2.4 Pathogenesis of coeliac disease

The pathogenesis of CD involves interaction between environmental, genetic, and immunological factors.

2.4.1 Environmental factors

2.4.1.1 Gluten and related proteins

Proteins in wheat, rye, and barley are environmental factors that are required for the development of CD. CD-activating proteins are collectively termed “gluten”, but, actually, gluten is the name for the CD-activating proteins (gliadin and glutenin subcomponents) in wheat. The closely related proteins in barley and rye are termed hordeins and secalins, respectively. Wheat, rye, and barley have a common ancestral origin, whereas oats is not so closely related to them (Kagnoff 2005). The proteins of oats, avenins, have a lower content of glutamines and prolines, and, rarely, if at all, activate CD (Janatuinen et al. 1995, Reunala et al. 1998, Janatuinen et al. 2002). Rice, maize, sorghum, and millet are still more distantly related and do not cause CD.

Gluten contains two major protein fractions, gliadins and glutenins. Toxic sequences are identified in both protein components of gluten as well as in similar proteins in rye and barley. High glutamine and proline contents of the gliadins, glutenins, hordeins and secalins play a key role in the pathogenesis of CD. Many gliadin peptides have shown to possess bulky hydrophobic amino acids followed by proline, which block the activity of intestinal peptidases (Arenz-Hansen et al. 2002). Shan et al. (2002) have recently identified a 33-amino-acid (33-mer) peptide, which is very resistant to digestion by gastric, pancreatic, and intestinal brush-border membrane proteases *in vitro* and *in vivo*. Furthermore, that peptide has a high affinity for tissue transglutaminase (tTG) enzyme, which has a central role in the pathogenesis of CD. After deamidation by tTG, the 33-mer peptide enters the APC. In the APC the peptide is processed to three epitopes, which bind to the HLA-DQ2 or HLA-DQ8 molecules and which have been previously shown to initiate an adaptive immune reaction with T-cell response in the small intestine of a CD patient (Lundin et al. 1993, Lundin et al. 1994). Homologs of this peptide have been found in all grains that are toxic to CD patients but were absent from non-toxic food grains, also from oats (Shan et al. 2002). Recent reports have suggested that certain gluten peptides, e.g. α -gliadin p31-43 or p31-49, might have direct toxic effects via innate immune system on the pathogenesis of CD, distinct from those recognised by T-cells on the intestinal epithelium (Maiuri et al. 2003, Hue et al. 2004).

The highest allowable daily intake of gluten by CD patients is a matter of debate. A daily consumption of < 50 mg, compared with an average of about 13 g in most Western countries, is considered safe by many experts (Schuppan et al. 2000, Collin et al. 2004, Hischenhuber et al. 2006). However, gluten sensitivity differs among individuals (Collin et al. 2004).

2.4.1.2 Other environmental factors

Apart from gluten, the interaction of environmental factors in CD is poorly understood. Breast feeding and the age when gluten is added to diet (Ivarsson et al. 2002), viral infections (Kagnoff et al. 1987, Monteleone et al. 2001, Stene et al. 2006, Zanoni et al. 2006), and smoking are some of the factors that might contribute to the development of CD (Vasquez et al. 2001).

2.4.2 Tissue transglutaminase enzyme

In 1997 the tTG enzyme was identified to be the target of endomysial antibodies (EMA), the presence of which is an indicator of CD (Dieterich et al. 1997, Dieterich et al. 1998). The tTG enzyme is an intracellular enzyme, found for example in fibroblasts, erythroblasts, mononuclear, and epithelial cells. During wounding, tTG is released to the extracellular space. The tTG is a multifunctional enzyme taking part in for example angiogenesis and wound healing. The tTG is also expressed on the subepithelial layer of intestinal epithelium, where tTG deamidates the glutamine residues in gliadin, resulting in negatively charged glutamic acids (Molberg et al. 1998). These deamidated peptides adhere strongly to the binding grooves of the HLA-DQ2 and DQ8 molecules, which present them to CD4+ lymphocytes and elicit strong T-cell responses (Molberg et al. 1998, van de Wal et al. 1998). Further studies revealed that tTG acts on only selected glutamines and that some gluten peptides became better binders to the DQ2 or DQ8 molecules after the deamination (Shan et al. 2002, Vader et al. 2002).

2.4.3 Immunological factors and the role of the HLA II genes

In some genetically susceptible individuals, ingestion of gluten or closely related proteins leads to infiltration of the intestinal mucosa by CD4+ lamina propria lymphocytes (the

activation of adaptive T-cell mediated immune response). In addition, the innate immune system is activated. These immune reactions together lead to crypt hyperplasia and villous atrophy (Figure 3).

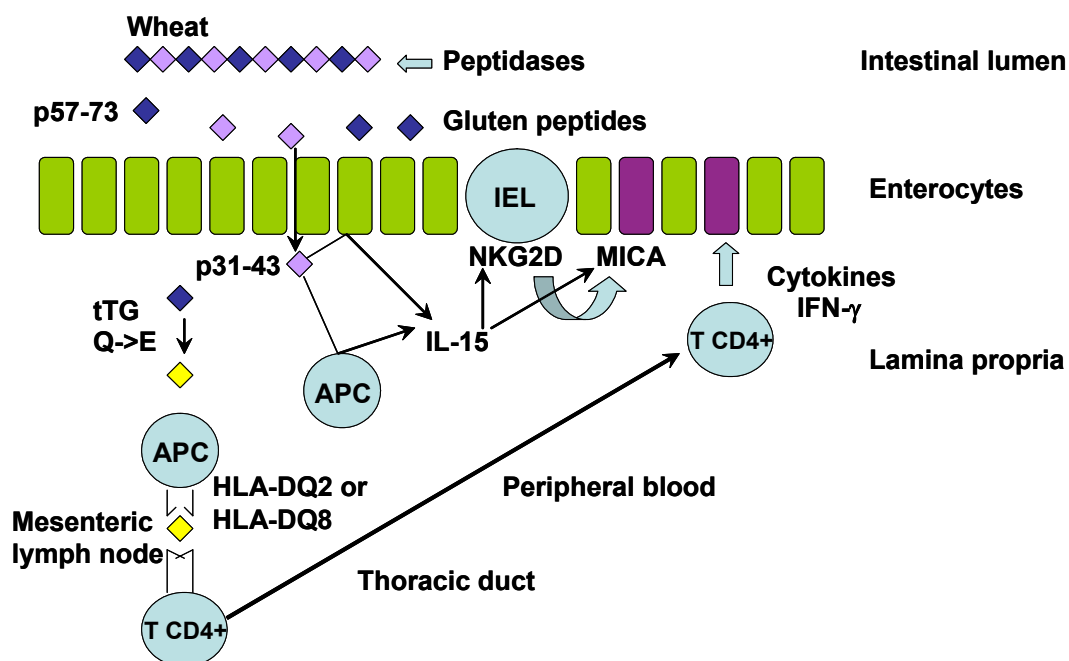

Figure 3. Pathogenesis of CD (modified from van Heel et al. 2006) is divided in three major series of events: luminal and early mucosal events, activation of pathogenic CD4+ T-cells, and subsequent events leading to tissue damage (Kagnoff 2005). Gluten is partially digested in intestinal lumen but the key toxic sequences are resistant to intestinal peptidases. In lamina propria, tTG deamidates the proline-rich peptides. APCs present these peptides to the DQ2 or DQ8 restricted populations of CD4+ T cells, which become activated and release cytokines that ultimately lead to tissue damage. Some gluten peptides, e.g p31-43/49 may directly induce IL-15 production from enterocytes and APCs. The increase in IL-15 levels leads to NKG2D and MICA upregulation on IELs and enterocytes, respectively, and results in enterocyte destruction. In addition, B-cell activation and humoral response are involved in the pathogenesis of CD.

CD4+ T-cells in the lamina propria recognise predominantly deamidated gluten peptides, which are presented to them by the genetically determined HLA-DQ2 or HLA-DQ8

molecules on the cell surface of APCs (Molberg et al. 1998). The x-ray crystal structure of DQ2 complexed with gliadin peptides provides an atomic explanation why DQ2 is capable of binding certain gluten peptides with high affinity (Kim et al. 2004). The peptide complexes are shown to activate DQ2 or DQ8 restricted T-cells, which can be isolated from the small intestine of patients with CD (Lundin et al. 1993, Lundin et al. 1994, Shan et al. 2002). Gluten-reactive CD4⁺ T cells produce cytokines and are likely to control the inflammatory reactions that produce the CD lesion (Sollid et al. 2005a). When activated, gluten-reactive CD4⁺ cells produce mainly Th1 type cytokines, most notably γ -interferon (IFN- γ) (Nilsen et al. 1995).

Recent studies suggest a role for innate immune system in the pathogenesis of CD. It is not clear which part of gluten stimulates the innate immune system, although a peptide 31-43 of a particular α -gliadin has shown to induce a rapid activation of factors in the innate immune system in biopsies of treated CD patients and increase the expression of interleukin (IL)-15 (Maiuri et al. 2003, Di Sabatino et al. 2006). IL-15 stimulates T cells to migrate to the epithelium and facilitate killing of enterocytes by upregulated expression of MIC by enterocytes and NKG2D by IELs (Maiuri et al. 2000, Maiuri et al. 2001, Mention et al. 2003, H ue et al. 2004). IELs are likely to be a key factor in the development of refractory CD and EATL (Cellier et al. 1998, Cellier et al. 2000). Involvement of infectious agents and innate immunity via activation of B-cells and humoral response has also been suggested to be involved in the pathogenesis of CD (Halttunen et al. 1999, Zanoni et al. 2006, Barone et al. 2007). Gluten also induces production of the intestinal peptide zonulin, which acts on junctions in mucosal epithelium and increases epithelial permeability (Clemente et al. 2003).

2.5 Clinical aspects of coeliac disease

2.5.1 Clinical features of coeliac disease

CD was originally thought to be a rare disease occurring mainly in childhood and expressing with overt symptoms related to GI tract and malnutrition (the classic CD). Later on it was understood that CD is underdiagnosed, can develop at any age, and has highly variable clinical manifestations. The classic CD is only the tip of the CD iceberg, and many CD patients have only mild or none GI symptoms (Collin et al. 1997, Mäki et al. 1997, Bottaro et al. 1999, Dewar et al. 2005). The prevalence in Western countries varies between 0.4-2.0 % based on serologic screening studies (Not et al. 1998, Fasano et al. 2003, Mäki et al. 2003, West et al. 2003, Dubé et al. 2005, Lohi et al. 2007). The pattern of incidence has changed, with a greater proportion of cases being diagnosed later in adulthood (Dewar et al. 2005). The recent increase in the incidence and the prevalence of CD seems not to be based only on increased awareness of CD and screening for CD (Lohi et al. 2007).

The clinical classification of CD is based on the presence of GI symptoms. The classic CD refers to presentations with diarrhoea, with or without malabsorption and malnutrition, whereas in atypical and/or silent CD, GI symptoms are absent or mild even though the patient might report other non-intestinal symptoms (Table 6). Diarrhoea occurs nowadays in less than 50% of patients, whereas in the 1960's it was present in almost all CD patients (Lo et al. 2003). Weight loss is now an uncommon feature of CD. In contrast, 30% of CD patients are overweight at the time of diagnosis (Dickey et al. 1998). Overall the onset of symptoms seems to be milder and there is often a considerable latency before the diagnosis of CD (Dewar et al. 2005).

Table 6. Clinical features of CD (Mäki et al. 1997, Dewar et al. 2005)

	Classic CD	Atypical or silent CD
GI-related symptoms	Diarrhoea / Steatorrhoea Abdominal distension Abdominal pain	Loose bowels / obstipation Flatulence Abdominal pain (mild) Abdominal distension (mild)
Malabsorption related symptoms	Lethargy Failure to thrive Anaemia Osteoporosis Weight loss Short stature	Anaemia Osteopenia/ osteoporosis
Other symptoms	Lymphoma	Neurological problems Infertility Other autoimmune disorders Dental enamel defects Aphthous stomatitis Arthralgia and arthritis Hepatological problems

Individuals with positive CD-specific serum antibodies, but with normal or minimally abnormal small bowel biopsy examination, have latent CD. The natural course of latent CD is unknown, but some individuals have been reported to develop CD with villous atrophy and clinical manifestations (Mäki et al. 1991, Collin et al. 1993, Högberg et al. 2003, Salmi et al. 2006a).

One explanation for the heterogeneity of symptoms of CD might be that the pathologic lesion of CD in small intestine develops gradually starting from proximal part of the small intestine and reaching finally the distal part. As a consequence, absorption in the small intestine is impaired. However, as the small intestine has a considerable functional reserve, many individuals with CD have few or no symptoms and no clinical evidence of malabsorption. Clinical presentation depends on the proportion of the small intestine affected, sensitivity to

gluten, the amount of gluten ingested, age, as well as other unknown factors (Dewar et al. 2005). The genes causing CD may, at least in part, explain different expressions of CD. So far, the dose of the HLA DQ2 haplotype or the *DQB1*0201* allele has been proposed to contribute to clinical features of CD (Table 2).

The mortality rate of CD patients exceeds that in the general population by a factor of 1.9-3.8; mainly due to malignant diseases (Logan et al. 1989, Cottone et al. 1999, Corrao et al. 2001, Catassi et al. 2005). The reduction in excess mortality after 1-5 years on GFD suggests that GFD has a protective effect against malignant disease in CD patients (Collin et al 1996, Catassi et al. 2005, Viljamaa et al. 2006).

2.5.2 Clinical features of dermatitis herpetiformis

DH is a cutaneous manifestation of CD, which usually erupts in adulthood. DH expresses with intensely pruritic papulovesicles and excoriations on the elbows, knees, buttocks, and scalp. Virtually all DH patients have at least minor changes in small bowel mucosa at the time of DH diagnosis, and about 20% of DH patients have a complete flattening of villi (Marks et al. 1966, Fry et al. 1969, Reunala et al. 1984, Zane 2005). Clinically, 10-20% of DH patients with CD have classic symptoms of CD, 20% have atypical symptoms, and at least 60% do not have GI symptoms of CD (Zane 2005). DH, as well as the associated enteropathy, is recovered with GFD. Dapsone improves DH for the period the medicine is used, but not the intestinal lesion (Reunala et al. 1977).

2.5.3 Diagnosis of coeliac disease and dermatitis herpetiformis

2.5.3.1 Small bowel biopsy

The first diagnostic criteria for CD were defined in 1969 by an expert board of the European Society for Paediatric Gastroenterology and Nutrition (ESPGAN). These criteria were modified in 1990 (Walker-Smith et al. 1990). The diagnosis of CD is based on typical histological changes seen in small bowel mucosal biopsy specimens, and on improvement of histological lesions or clinical symptoms or both on GFD. The biopsies are obtained from the proximal part of small bowel usually by esophago-gastro-duodenoscopy (EGD), sometimes by a capsule technique or by push enteroscopy. Several well-oriented (not tangential) biopsies of adequate size should be taken because CD lesions might be patchy (Dewar et al. 2005). An intestinal biopsy should be undertaken if serological analysis is suggestive for CD or if serological tests are negative, but clinical suspicion is high. Duodenal biopsies should be taken routinely in EGD done for any reason, because the endoscopic appearance is often normal in CD and the clinical pattern of CD is heterogenous (Dickey et al. 2001, Collin et al. 2002).

The histological lesion related to CD develops gradually (Roy-Choudhury et al. 1966, Marsh 1992) (Figure 4). First there is an infiltrative (Marsh I) lesion, which comprises normal mucosal architecture with increased level of IELs. After that there is a hyperplastic (Marsh II) lesion, which is similar to Marsh I lesion, but with the addition of elongated crypts. After that a destructive (Marsh III) lesion develops, which correlates with classic villous atrophy of CD. The villous atrophy has been further divided to partial (Marsh IIIa), subtotal (Marsh IIIb), and total (Marsh IIIc) villous atrophy (Rostami et al. 1999). Finally, a hypoplastic (Marsh IV) atrophy of mucosa might develop. The Marsh IV stage has been suspected to be a predisposing stage for EATL (Marsh 1992).

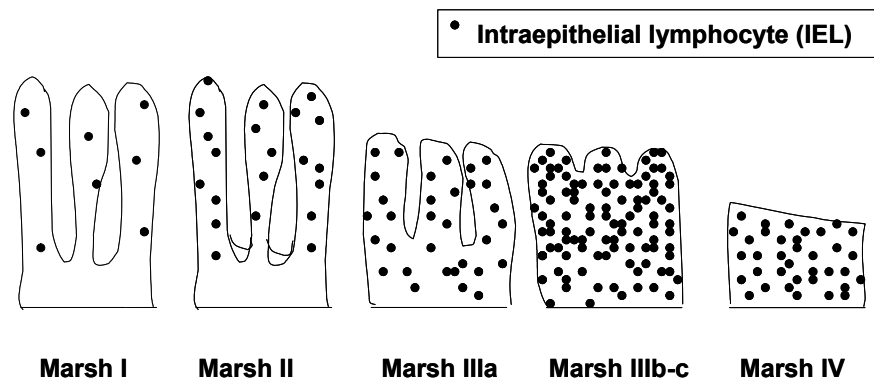

Figure 4. Development of the histological lesion of CD according to Marsh (1992).

A histological villous atrophy (Marsh III) is the criterion for the diagnosis of CD, although this requirement probably overlooks many subjects who are actually gluten-sensitive (Collin 1999). On the other hand, although CD is the most common reason for villous atrophy in the small intestine, some other conditions must be borne in mind in differential diagnosis of CD, especially in cases with negative CD-specific serology and/or with mild mucosal changes. Conditions to be considered include autoimmune enteropathy, Crohn's disease, collagenous sprue, infective gastroenteritis, bacterial overgrowth, giardiasis, tuberculosis, tropical sprue, Whipple's disease, lactose intolerance, soya protein intolerance and other food allergies, anorexia nervosa, ischemic enteritis, Zollinger-Ellison syndrome, intestinal lymphoma, hypogammaglobulinemia, human immunodeficiency virus enteropathy, and other immunodeficiency states (Dewar et al. 2005).

2.5.3.2 Skin biopsy

A skin biopsy to detect DH is performed from normal-appearing, perilesional skin. Characteristic finding in DH is the presence of granular immunoglobulin (Ig)-A in dermal papillary tips (Van der Meer 1969).

2.5.3.3 Serological testing

Positive serological tests support the diagnosis of CD, but are not required for the diagnosis. On the other hand, the diagnosis of CD can not be based only on positive serology. Similarly, negative serology does not exclude CD. However, especially in the absence of positive serology, other causes of villous atrophy must be considered in the differential diagnosis. The correlation of the presence of positive antibodies with the degree of villous atrophy is controversial. In some studies, serological tests have been negative in patients with partial villous atrophy (Rostami et al. 2000, Abrams et al. 2004), whereas in a Finnish study EMA was negative in the case of advanced CD (Salmi et al. 2006b). Positive serological tests normalise during GFD and can thus be used as a part of a follow-up programme of CD patients although serological tests seem not to be perfect to recognise villous lesions during GFD (Sategna-Guidetti et al. 1993, Kaukinen et al 2002b). In addition, serological tests can be used as a screening test for CD in individuals with GI symptoms and in certain high-risk groups (Collin 2005).

EMA and tTG IgA-antibodies are the most sensitive and specific serological tests available for CD. Sensitivity of EMA-IgA varies between 86-100% and specificity between 97-100%, and sensitivity of tTG-IgA varies between 77-100% and specificity between 83-100% (Hill 2005). The guinea pig protein tTG is clearly less sensitive than is the human recombinant protein tTG (Hill 2005). Sensitivity and specificity of IgA-antigliadin antibodies (AGA) have been not only highly variable, but also generally lower than those for EMA and tTG (sensitivity 52-100%, specificity 71-100%) with sensitivity over 90% in 7 of 26 studies and specificity over 90% in 19 of 26 studies in a meta-analysis involving 1996 patients with CD and 2841 controls (Hill 2005). Antireticulin antibodies (ARA) are currently not used mainly

because of low sensitivity (42-100%) (Collin 1999). IgG-antibodies should be used in diagnostic purposes in the case of selective IgA-deficiency (Hill 2005). Standardisation of antibody tests between different laboratories is important. Human recombinant tTG-IgA antibody test is probably the best test for the screening of CD, as it is easiest to perform. In addition, it has good sensitivity and specificity (Sulkanen et al. 1998b), and it is less observer dependent and cheaper than EMA (Collin 2005). In future, the deamidated gliadin peptide antibody test might be useful in detecting CD (Kaukinen et al. 2007).

2.5.3.4 HLA genotyping

Because over 99% of CD patients share at least one of the CD associated HLA alleles (Karell et al. 2003), the HLA genotyping can be used in certain circumstances to exclude the possibility of CD (for example in patients with equivocal biopsy results or negative serological test, or for patients already on GFD without a proper diagnosis of CD) (Kaukinen et al. 2002a).

2.5.3.5 Other tests

An increase in small bowel IELs, especially $\gamma\delta$ T-cell receptor bearing cells, is typical, but not pathognomonic for CD (Collin 1999, Järvinen et al. 2003). Counting IELs is recommended in some borderline cases where histology is difficult to interpret. In the future the analysis of villous tip IELs or small-bowel mucosal transglutaminase 2 –specific IgA deposits might be helpful in detecting CD, especially at early stages of the disease and in patients with seronegative villous atrophy (Järvinen et al. 2004, Kaukinen et al. 2005, Salmi et al. 2006a).

2.5.4 Screening for coeliac disease

Because the symptoms of CD are diverse or absent, screening for CD in some high-risk populations has been recommended. In contrast, population based screenings has not been accepted because the natural course and the complications of the silent CD are unclear, the diagnosis of CD and GFD might deteriorate the quality of life, adherence to GFD might be low, the cost-effectiveness of the screening is unclear, and the possibility of false-positive antibody tests is higher than in the high-risk groups (Collin 2005, Cranney et al. 2005, Hoffenberg 2005). However, a recent study reported good quality of life and adherence to GFD in risk group screen -detected, asymptomatic patients with CD during a 14-year follow-up (Viljamaa et al. 2005).

The prevalence of CD in high risk populations is up to 20% in first-degree relatives, 3-15% in iron-deficiency anemia, 3-6% in type 1 diabetes, and 1-3% in osteoporosis (Dubé et al. 2005). In various autoimmune diseases, the risk of CD is about 5% (Collin et al. 2002). In some other conditions like infertility, neurological symptoms, elevated aminotransferases, liver failure, lactose intolerance, irritable bowel syndrome, and Down syndrome, the prevalence of CD is increased (Collin 2005, Dubé et al. 2005).

Serological testing for CD antibodies is the most popular strategy to screen for CD. AGA and ARA tests have been widely used for screening previously, but recently the benefits of EMA and tTG tests have been noted. However, serological screening misses some cases of CD (Rostami et al. 1999, Dickey et al. 2000, Tursi et al. 2001, Abrams et al. 2004). Screening by EGD and duodenal biopsies is more reliable, but as EGD is an invasive and expensive method, it is saved for situations of high clinical suspicion of CD. Sometimes even EGD misses CD because of bad orientation or small size of duodenal mucosal biopsies or patchy

duodenal lesions of CD (Dewar et al. 2005). Genotyping for the HLA-alleles associated with CD could be used to exclude the possibility of CD (when negative) (Csizmadia et al. 2000, Kaukinen et al. 2002a, Hadithi et al. 2007), but it has not been studied in this purpose in family-based studies. In contrast, an identification of HLA risk allele does not help much in the screening, because most individuals carrying the CD-associated HLA-alleles will never develop CD (Liu et al. 2002). The best timing of screening is unclear in asymptomatic high-risk individuals.

2.5.5 Treatment of coeliac disease

At present, the only available treatment for CD is life-long adherence to a strict GFD. However, the compliance to GFD is not perfect in a large proportion of patients (Sollid et al. 2005a). In many countries, the availability of gluten-free products is not good, and the products are more expensive than gluten-containing counterparts. Recent advances in understanding of the pathogenesis of CD have given rise to the development of potential new therapies, e.g. oral enzyme supplementation, transamidation of wheat flour, tTG inhibitors, HLA-DQ2-blockers, cytokine therapy, selective adhesion molecule inhibition, and others (Sollid et al. 2005a, Gass et al. 2007, Gianfrani et al. 2007).

3. AIMS OF THE STUDY

The general aim of this study was to investigate the genetic background and phenotype characteristics of CD in Finnish families. In addition, different screening methods for CD in families were investigated. The specific aims of different studies were:

1. To perform a genome-wide scan to identify susceptibility loci for CD.
2. To investigate whether a gene dose effect of the *DQA1*0501* allele or the *DQB1*0201* allele contributes to the severity of CD.
3. To investigate whether HLA genotyping is useful in the evaluation of the risk of CD in first-degree relatives of patients with CD.
4. To compare different screening methods for CD with special emphasis on the initial HLA genotyping in the first-degree relatives.

4. SUBJECTS AND METHODS

4.1 Subjects and study design

4.1.1 Index patients

All subjects participating in this study were Finnish. The prevalence of CD in Finland has been estimated to be about 1:270 (Collin et al. 1997) or even 1:100-1:50 (Mäki et al. 2003, Lohi et al. 2007). The Kuopio University Hospital region in Eastern Finland covers a population of 250 000. Thus, the expected number of CD patients in this region is about 900-5000. The index patients for this study were selected from CD and DH patients diagnosed and/or treated at Kuopio University Hospital until 1996. The criteria for a selection was a definite diagnosis of CD and/or DH according to the following criteria: Small bowel mucosal biopsy with total, subtotal, or severe partial villous atrophy with crypt hyperplasia, or skin-biopsy-proved DH. In severe partial villous atrophy also positive AGA and/or EMA and/or ARA and/or biopsy-proved DH was required. The majority of patients had a follow-up biopsy demonstrating mucosal recovery on a GFD, and all patients recovered from symptoms of CD and/or DH.

Altogether 428 patients (330 CD and 98 DH) fulfilled the diagnostic criteria (Walker-Smith et al. 1990). The patients with CD represented mainly the classic form of CD rather than the asymptomatic or atypical form. To find CD families for a genome-wide scan, the relatives of the index patients were investigated as described below.

4.1.2 Study protocol

The index patients were sent a questionnaire asking the CD and DH -status of their first and second -degree relatives. The response rate was 71% (304/428) (Figure 5).

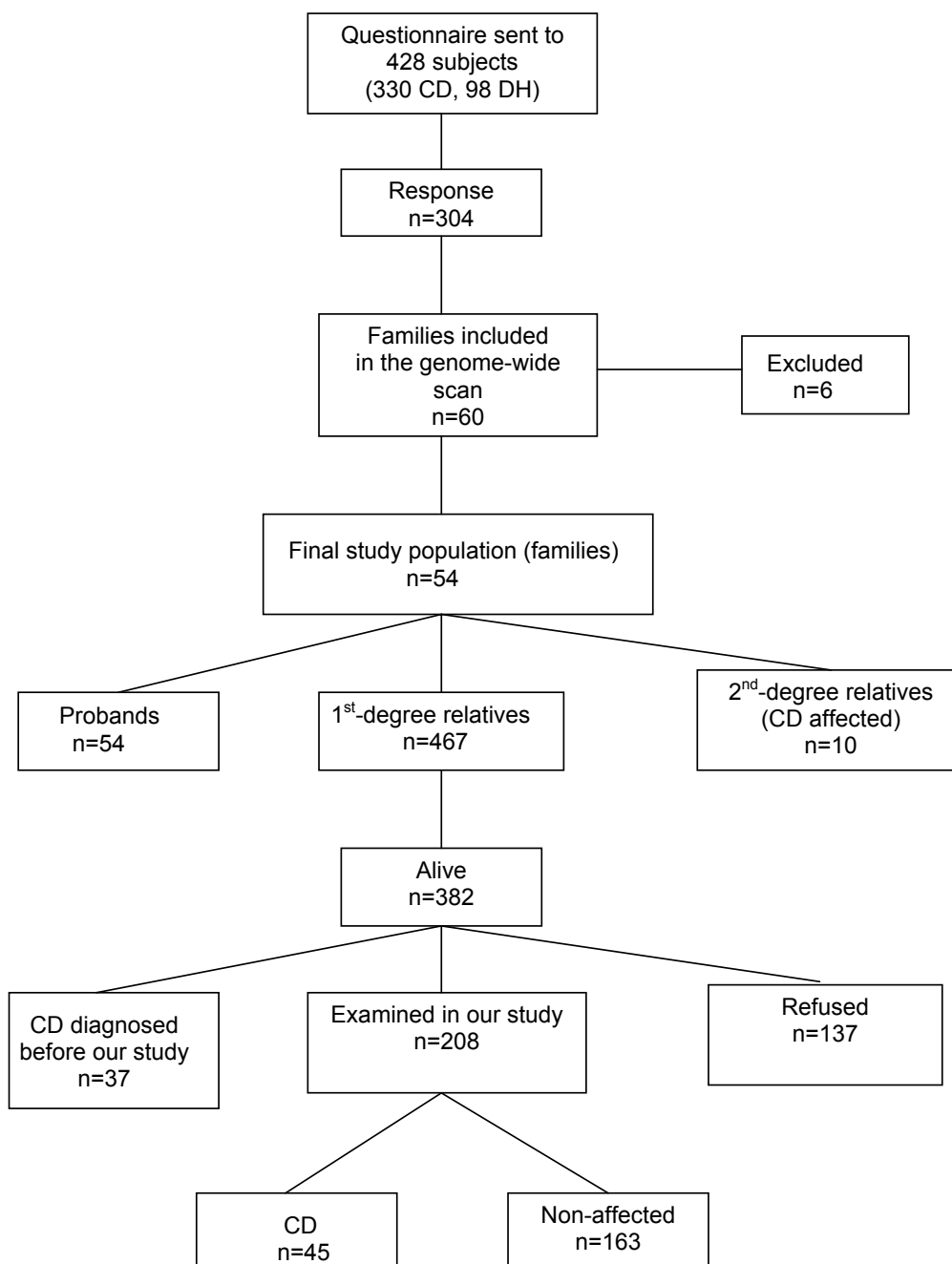

Figure 5. Flowchart of the Study protocol.

First, those families including at least two subjects with CD were investigated. All first-degree relatives of patients with CD (parents, siblings, and offspring) were invited to an examination, which included EGD with duodenal biopsies, a skin biopsy, CD antibody-testing, other laboratory tests, and a questionnaire about the symptoms. The diagnoses of CD of family members, who had been diagnosed before the present study, were re-evaluated by scrutinizing the medical records. A venous blood sample for DNA analyses was obtained from the index patients and from all relatives who participated in this study. For those who refused from EGD, CD antibody testing and a blood sample for DNA were offered. If a relative was diagnosed to have CD also the first-degree relatives of that individual were invited to examination.

Secondly, to get enough families for a genome-wide screening, those families where the index patient was the only subject having CD were investigated. Siblings of the index patients were offered antibody tests for CD (AGA, ARA, EMA). If any of the antibodies were positive, the sibling was examined as described above (duodenal and skin biopsies, blood samples, questionnaire). If the sibling was found to have CD, the other first-degree relatives were similarly examined. All family members were clinically examined in 1996-1999.

4.1.3 Families participating in the genome-wide scan (Study I)

Any family to be included in the genome-wide scan to identify susceptibility genes for CD, had to have at least two siblings with CD fulfilling the diagnostic criteria mentioned above. However, DH without villous atrophy was not sufficient for the diagnosis of CD and they were excluded. A total of 60 families fulfilled the criterion. Based on the genome scan, six families were excluded (monozygote twins in one family, half-siblings in two families, and Mendel/sample errors in three families). Thus, the final study population consisted of 54

families including 146 CD patients (41, 10, and 3 families had 2, 3, and 4 affected siblings, respectively). Altogether 146 CD patients and 104 healthy first-degree relatives were included in the genome-wide scan.

4.1.4 Coeliac disease patients participating in the Study II

The study population of Study II consisted of CD patients (n=146) who were included in the genome-wide scan. Two of CD patients were excluded because of slight partial villous atrophy with positive CD antibodies, thus 144 CD patients (127 with CD, 88.2%, and 17 with CD and DH) were included. Mean age at the diagnosis of CD was 42.5 +/- 15.5 (range 1-79) years. Most of CD patients (94.4%) were adults (>17 years old) at the time of diagnosis (59.7% women, 40.3% men).

4.1.5 Families participating in the Study III

The study population consisted of the aforementioned 54 CD families. The probands (n=54) and all first-degree relatives examined (n=245) were included (82 affected and 163 non-affected). The second-degree relatives of the probands were excluded. The mean age of CD patients at diagnosis was 43.7±14.7 (range 1-79) years; 95.6% of them were adults at diagnosis. Of CD patients, 58.8% were women. The characteristics of the first-degree relatives are shown in Table 7.

Table 7. The characteristics of the first-degree relatives of probands with CD (III).

	N	Gender n (M/F)	Alive n (%)	Included in the study* n (%)	Coeliac disease n (%)	Age mean \pm std (range)
Parents of probands	108	54 / 54	39 (36.1)	17 (15.7)	5 (4.6)	65.6 \pm 6.7 (51-77)
Siblings of probands	255	120 / 135	239 (93.7)	166 (65.1)	69 (27.1)	49.5 \pm 12.9 (13-79)
Offspring of probands	104	53 / 51	104 (100)	62 (59.6)	8 (7.7)	25.5 \pm 9.7 (3-45)
Altogether	467	227 / 240	382 (81.8)	245 (52.5)	82 (17.6)	

*Duodenal biopsy and HLA genotyping

4.1.6 First-degree relatives participating in the Study IV

The study population consisted of those first-degree relatives of the aforementioned 54 CD families who had been examined in this study (n=208). First-degree relatives who were diagnosed to have CD before this study (n=37) were excluded. In addition, 19 of the first-degree relatives were excluded because they lacked a questionnaire about GI symptoms. Thus, the final study population included 189 subjects (42 subjects with CD and 147 first-degree relatives without CD). The mean age of the study population was 45.0 ± 17.1 (range 8-77), and 60.3% of them were women.

4.2 Methods

4.2.1 Esophago-gastro-duodenoscopy

EGD was performed with an Olympus GIF-20 or an Olympus GIF-30 gastroscope (Tokyo, Japan) (adults) or with an Olympus GIF-XQ30 gastroscope (Tokyo, Japan) (children under 10 years old). The biopsies were taken with an Olympus FB-13K jumbo forceps (Tokyo, Japan) (adults) and an Olympus FB-24K forceps (Tokyo, Japan) (children under 10 years). Altogether seven biopsies were taken from the proximal small intestine (five from the distal part of duodenum and two behind the bulbar part of duodenum). Two distal-duodenal biopsies and two post-bulbar biopsies were used for histological evaluation.

4.2.2 Duodenal biopsies

Endoscopic duodenal biopsy specimens were fixed in 10% buffered formalin and processed by standard methods. The staining method used was van Gieson's (Bradbury et al. 1982). Specimens were oriented with the aid of a dissecting microscope to get well-oriented villi in the histologic sections. The degree of crypt hyperplastic villous atrophy was graded as total, subtotal, partial (severe or slight), or normal (Roy-Choudhury et al. 1966, Janatuinen et al.

1995). No villous projections from the surface were seen in total atrophy, and in subtotal atrophy villi were almost completely absent. In slight partial atrophy, some villi were slightly broadened and shortened, whereas in severe partial atrophy villi were more damaged and almost corresponded to that seen in subtotal atrophy. The same pathologist conducted all duodenal histopathological examinations and re-evaluated all duodenal biopsy specimens taken before this study.

4.2.3 Skin biopsy

A skin biopsy was taken from uninvolved skin using a Stiefel-punch (\varnothing 3mm) under local anesthesia (4-5 ml Lidocain 10mg/ml –Adrenalin). After removal, skin biopsy specimens were embedded in Cryomatrix (Shandon Inc., Pittsburgh, PA, US) and frozen in isopentane cooled with a mixture of absolute ethanol and dry ice. Cryosections of 4 μ m thickness were cut into 6 uncoated slides and stored at -20°C until stained. The slides were stained with antibodies directed towards IgA, IgG, IgM, fibrinogen and complement C3c. Also a control antibody against IgA+IgG+IgM+kappa+lambda was applied. All antibodies were FITC-conjugated and purchased from DAKO (Glostrup, Denmark). All slides were stained in Techmate 500 automated immunostainer (DAKO, Glostrup, Denmark) using the direct immunofluorescence (IF) method. The slides were examined with a Leitz Dialux 22 microscope equipped with an epifluorescence system (Leica, Nussloch, Germany). Antibody staining results were marked as - (negative), + (slightly positive), ++ (clearly positive), +++ (strongly positive). A granular deposition of IgA in the dermal papillae (clearly or strongly positive IgA antibody staining) was the diagnostic criterion used for DH. All biopsies were examined by the same investigator.

4.2.4 Serology

All antibody tests of the family members were performed in the same laboratory (Institute of Medical Technology, University of Tampere, Finland). For those family members, who were diagnosed to have CD before this study, the antibody parameters were recorded at the time of diagnosis if available.

IgA-class EMA were measured by means of indirect IF method, using unfixed cryostat sections of full-term human infant umbilical cord as antigen (Ladinsler et al. 1994, Volta et al. 1995, Sulkanen et al. 1998a). IgA-class ARA were examined by using a composite block of rat kidney, liver, stomach, and heart as antigens (Hällstöm 1989). Patient sera were screened for IgA-class EMA and ARA at dilutions of 1:5 and 1:50 with fluorescein isothiocyanate-conjugated monospecific goat antiserum to human IgA (Kallestad Diagnostics, Chaska, Minn., USA). Positive sera were further titrated 1:50, 1:100, 1:200, 1:500, 1:1000, 1:2000, 1:4000, and 1:8000. All dilutions of sera were made in phosphate-buffered saline, pH 7.2-7.4. Positive and negative controls were included in every test batch. Sections were examined by fluorescent incident light microscopy. EMA positivity included a specific honeycomb-like fluorescence around the smooth-muscle fibres in the muscularis mucosa of the vessels. The ARA test was considered positive when the characteristic R1-type ARA pattern was found.

IgA- and IgG-class AGA were measured with a solid-phase enzyme-linked immunosorbent assay (ELISA) with a crude gliadin preparation as antigen, as previously described (Savilahti et al. 1983). The results were obtained from a standard curve established on the basis of dilutions of a positive reference serum and converted to concentrations of arbitrary ELISA units per millilitre (EU/ml). Patient and control sera with AGA in higher concentrations of EU/ml than known healthy controls (mean plus two standard deviations) used in the

laboratory were considered positive; the cut-off level was 0.2 EU/ml for IgA-class AGA and 10.0 EU/ml (adults) and 15.0 EU/ml (children) for IgG-class AGA.

4.2.5 Other laboratory tests

A venous blood sample for laboratory tests (B-haemoglobin, mean cellular volume of erythrocytes, fS-iron, fE-folate, fP-calcium, S-albumin, S-IgA, S-IgM, S-IgG) was obtained from all subjects in this study. For those family members, who were diagnosed to have CD before this study, the laboratory parameters were recorded at the time of diagnosis if available. In addition, a blood sample (36 ml adults and 18 ml children under 10 years) for DNA analyses was taken.

4.2.6 Questionnaire for symptoms

A questionnaire for the symptoms and previous diseases was obtained. The symptoms were classified as follows: 1. mild: not disturbing daily life, 2. moderate: disturbs daily life, but does not prevent from working, or 3. severe: prevents working, needs medication. For those family members, who were diagnosed to have CD before this study, the questionnaire was recorded if available.

4.2.7 HLA genotyping

DNA was prepared from blood leucocytes using the salting-out method (Miller et al. 1988). The presence of the DQ2 alleles *DQA1*0501* and *DQB1*0201* and the presence of the DR4 allele *DRB1*04* as well as control fragment AC-2 were identified by a rapid PCR-based identification method (Sacchetti et al. 1997). The following primers were used: *DQA1*0501* forward 5'-AGC AGT TCT ACG TGG ACC TGG GG-3', *DQA1*0501* reverse 5'-GGT

AGA GTT GGA GCG TTT AAT CAG A-3', *DQB1*0201* forward 5'-GCG GTG CGT CTT GTG AGC AGA AG-3', *DQB1*0201* reverse 5'-GGC GGC AGG CAG CCC CAG CA-3', *DRB1*04* forward 5'-GGT TAA ACA TGA GTG TCA TTT CTT AAA C-3', *DRB1*04* reverse 5'-GTT GTG TCT GCA GTA GGT GTC-3', AC-2 forward 5'-GCA GAG TAC CTG AAA CAG GA-3' and AC-2 reverse 5'-CAT TCA CAG TAG CTT ACC CA-3'.

Multiplex PCR reactions were carried out as follows:

DQ2 alleles; The 11 µl reaction mixture consisted of 50 ng of genomic DNA, 3 pmol of each primer (*DQA1*0501* forward and reverse, and *DQB1*0201* forward and reverse), 10% buffer III with 20 mM of MgCl₂ and pH of 8,0 (PCR Optimisation Kit: MBI Fermentas, Vilnius, Lithuania), 100 µM dNTPs and 0,13 units of DNA polymerase (recombinant Taq DNA polymerase; MBI Fermentas, Vilnius, Lithuania).

DR4 alleles; The 10 µl reaction mixture consisted of 50 ng of genomic DNA, 6 pmol of each primer (*DRB1*04* forward and reverse, and AC-2 forward and reverse as control primers), 10 mM Tris-HCl (pH 8,8), 50 mM KCl, 1,5 mM of MgCl₂, 0,1% Triton X-100, 100 µM dNTPs and 0,15 units of DNA polymerase (Dynazyme DNA polymerase; Finnzymes, Espoo, Finland). The PCR conditions were as follows: initial denaturation at 95°C for 5 minutes (min), followed by 30 cycles of denaturation at 94°C for 30 seconds (s), annealing at 60-64°C for 10 s, and extension at 72°C for 20 s; and a final extension at 72°C for 10 min. After PCR reaction the samples were run on 9% polyacrylamide gel stained in ethidiumbromide and photographed. The length of amplified PCR products were 144 bp in *DQA1*0501* allele, 110 bp in *DQB1*0201* allele, 177 bp in *DRB1*04* allele and 491 bp in control fragment (AC-2).

The single-strand conformation polymorphism analysis (SSCP) method was used to separate heterozygous and homozygous DQ2 allele carriers (Orita et al. 1989). The following

previously published primers were used in PCR reactions: DQA forward 5'-GGT GTA AAC TTG TAC CAG T-3', DQA reverse 5'-GTA GCA GCG GTA GAG TTG-3' and DQB forward 5'-CAG ACA CAT CTA TAA CCG A-3', DQB reverse 5'-CTC GTA GTT GTG TCT GCA-3' (Clay et al. 1995). SSCP reaction mixture of 6 μ l consisted of 50 ng of genomic DNA, 3 pmol of each primer (DQA forward and reverse; DQB forward and reverse), 10 mM Tris-HCl (pH 8.8), 50 mM KCl, 1.5 mM of MgCl₂, 0.1% Triton X-100, 100 μ M dNTPs, 0.14 units of DNA polymerase (Dynazyme DNA polymerase; Finnzymes, Espoo, Finland) and 0.55 μ Ci of α -³³P dCTP (NEN Life Science Products, Boston, Massachusetts, US). The PCR conditions were as follows: initial denaturation at 94°C for 3 min, followed by 30 cycles of denaturation at 94°C for 30 s, annealing at 50°C for 45 s, and extension at 72°C for 30 s; and a final extension at 72°C for 10 min. The PCR products were first diluted 4-fold with 0.1% sodium dodecyl sulphate (SDS) and 10 mM EDTA and after that diluted (1:1) with loading mix (containing 95% formamide, 20 mM EDTA, 0.05% bromophenol blue and 0.05% xylene cyanol). After denaturation at 98°C for 3 min, samples were immediately cooled on ice. A total of 3 μ l of each sample was loaded onto a 6% non-denaturing polyacrylamide gel (acrylamide/N,N-methylene-bis-acrylamide ratio 49:1) containing 10% of glycerol. The runs were performed at two different gel temperatures: 38°C for 4 hours (h) and 29°C for 5 h. The dried gels were autoradiographed at -20°C for one to five days. The results of the SSCP analysis were verified by sequencing genomic DNA from individuals with different SSCP patterns using ABI Prism BigDye Terminator Cycle Sequencing Ready Reaction Kits and ABI Prism 310 Genetic Analyzer (Applied Biosystems, Foster City, California, US).

4.2.8 Genome-wide scan

Genomic DNA was extracted from peripheral blood lymphocytes from affected and unaffected family members. Parental DNA samples were typed when available: 17% of the families had both parents and 33% had one parent. Unaffected siblings were also typed in 67% of the families missing both parental DNA samples. Genotyping was performed by use of a modified version of the Co-operative Human Linkage Center (CHLC) Human Screening Set/version 6.0 panel of polymorphic markers (Dubovsky et al. 1995). Specifically, the screening set comprised 312 fluorescently labelled genetic markers (Research Genetics) with average heterozygosity of .75 and average spacing between markers of 12 cM (Rioux et al. 1998).

PCR-reactions were set up with a robotic pipetting station (Rosys Robotic Systems) in thin-walled 192-well polycarbonate plates (Corning Costar). Reactions were overlaid with light mineral oil (Sigma Chemical) and were amplified on custom-built thermocyclers (Intelligent Automation Systems), each accommodating 16 192-well plates. PCR products were then multiplexed into panels by pooling (average of eight markers/panel) based on allele-size range and fluorescent label. Aliquots of the multiplexed samples were mixed with either Tamra-labelled GENESCAN 500 and GENESCAN 2500 (Perkin Elmer Applied Biosystems) or rhodamine-labelled MapMarkers (Bioventures) and then were run on ABI377 sequencers (Perkin Elmer Applied Biosystems) (Rioux et al. 1998).

Fluorescent genotyping gels were analysed in an automated system developed at the Whitehead Institute/Massachusetts Institute of Technology (MIT) Center for Genome Research. The gels were tracked automatically and reviewed manually by use of the Bass/Grace gel-analysis system. Alleles were called automatically by use of software that

implements strict guidelines (to prevent miscalls due to leakage, mistracking, weak signal, or detector saturation) and that identifies alleles based on their characteristic response (including A+ and stutter bands). Sizes were determined automatically by comparison with the size standards loaded on every lane. Control genotypes were included on every gel, to ensure accuracy and reproducibility of allele calling. Gels, pedigrees, and markers with aberrantly large numbers of Mendelian-inheritance errors were re-examined carefully to monitor any systematic laboratory or sample mix-ups and to ensure that each fluorescent marker was producing a consistent assay. The automated genotyping system also was monitored frequently by comparison with manual genotype calls, to ensure consistent performance.

The NPL analysis of data from the genomewide scan was performed with CD (with or without DH) as the phenotype using Genehunter 2.0. To establish appropriate thresholds for suggestive (i.e., the score expected to occur one time at random in a genomewide scan) and significant (i.e., the score expected to occur one time at random in 20 genomewide scans) genomewide linkage for this particular dataset, simulations were performed by generating artificial genotype data with identical family structures (Gensim computer program). These simulations matched our dataset with respect to marker density, marker informativeness, individuals genotyped, affected status, and fraction of missing data. These genome scan simulations were performed by generating random genotypes for pedigree founders and passing them on at random under the hypothesis of no linkage and using the recombination distances and marker density and heterozygosity of the actual dataset. Ungenotyped individuals remained so in the simulated data and missing genotype data was inserted at random at the rate at which it occurred in individuals available for genotyping. One thousand genome screens were generated at the genome scan marker density (one marker every 10 cM throughout). In this manner, the genomewide thresholds for suggestive and significant linkage

resulted in Z scores of 1.9 and 2.7, respectively. These empirical thresholds are lower than the theoretical thresholds 2.9 and 4.1, respectively, reported by Lander and Kruglyak (1995), since the theoretical thresholds are based on an infinitely dense genetic map, a particular family structure and perfect information.

Association testing was performed in this sample by randomly selecting a single discordant sib-pair from each family and performing a sib-TDT (in this form a pure test of association). These results were combined with other TDT and case-control studies by reformatting the results of each study as a mean, observed, and variance on the number of risk alleles transmitted (i.e., in studies using trios) or found in cases (i.e., in case-control studies). A combined Z score and P value were then computed using summation. Odds ratios (ORs) and pooled ORs were computed using the logit method as described by Morris and Gardner (1988).

4.2.9 *CTLA-4* genotyping

The exon 1 polymorphism (+49*A/G) of the *CTLA-4* gene was typed using standard PCR allele specific dot blot hybridisation with PCR primers (forward 5'-GCTCTACTTCC TGAAGACCT-3' and reverse 5'-AACCCAGGTAGGAGAAACAC-3'; 35 cycles of 30 s at 94°C for denaturing, 30 s at 50°C for annealing, and 60 s at 72°C for extension) and detection oligonucleotides (5'-AACCTGGCTGCCAGGACC-3' and 5'-AACCTGGCTACCAGGACC-3') (Djilali-Saiah et al. 1998). The presence of the G allele of *CTLA-4* position 49 polymorphism was confirmed by digestion of the PCR product with the restriction endonuclease BbvI and visualisation of the fragments on 2.5% agarose gels stained with ethidium bromide.

Allele and phenotype frequencies were determined. ORs were calculated according to Woolf's formula, and the p value was defined by chi-square (χ^2) analysis using a 2x2 or 2x3 contingency table, or Fisher's exact test where appropriate. A value of $p < 0.05$ was considered significant.

4.2.10 Statistical methods

All statistical analyses were performed with the SPSS for Windows program (version 11.0 or 11.5, SPSS Inc., Chicago, Illinois, USA). The results are given as mean \pm SD, or percentages. The effect of the *DQA1*0501* and *DQB1*0201* alleles on the grading of villous atrophy at the time of diagnosis and after one year of GFD in Study II was tested with the χ^2 test. Furthermore, the differences in GI symptoms between the different study groups in Study IV were tested with the χ^2 test. A p-value less than 0.05 was considered statistically significant.

The differences in variables (age at diagnosis, laboratory parameters, GI symptoms) among the CD patients with different HLA genotypes and haplotypes in Study II were tested with the linear regression with the program ASSOC (S.A.G.E., version 2.2, Ohio, US) (George et al. 1987). The ASSOC program allows the quantitative trait to have familial correlation among individuals. The likelihood for the pedigree is computed with a linear regression model in which the quantitative trait is the dependent variable and genetic variation and discrete and/or continuous covariates are independent variables. Residual variation is modelled assuming an additive polygenic pattern of correlation among relatives. By the use of this model, the likelihood for each pedigree was maximised twice, with and without the genetic HLA polymorphism in the model. The difference in natural logarithms of these 2 maximised likelihoods follows the chi-square distribution from which the corresponding p-value is taken with 2 degrees of freedom (three groups of HLA genotypes). Linkage disequilibrium between

the variants in the Study II was estimated using the program EH (<http://linkage.rockefeller.edu/ott/eh.htm>).

4.3 Approval of the Ethics Committee

The study was approved by the Ethics Committee of the Kuopio University Hospital and the University of Kuopio. All subjects gave informed consent and all samples were collected according to the World Medical Association Declaration of Helsinki (WMA, 2002).

5. RESULTS

5.1 Genome-wide scan to identify susceptibility loci or genes for coeliac disease

(Study I)

In a multipoint NPL analysis of the genome-wide scan two chromosomal regions were found to have significant evidence of linkage to CD (6p; peak NPL 3.0 at D6S1281, $p=0.0016$, and 2q23-32; peak NPL 2.8 at D2S1776, $p=0.003$), and one region had suggestive linkage to CD (10p; peak NPL=1.93 at D10S674; $p=0.028$) (Figure 6).

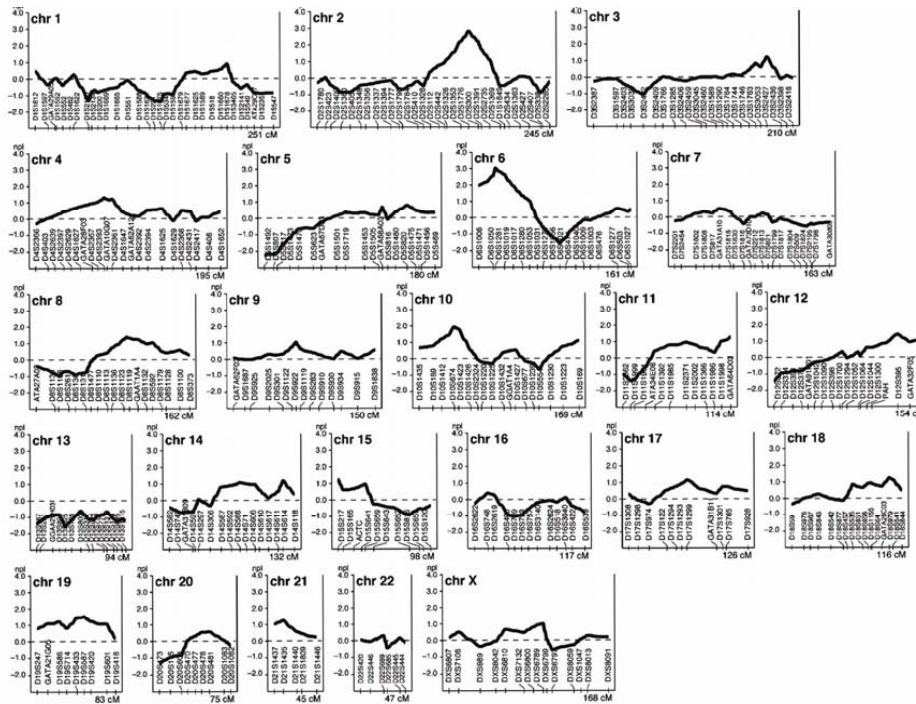

Figure 6. Multipoint linkage analysis results for the genome-wide scan for predisposing genes for CD (I). NPL scores were calculated using the Genehunter 2.0 software. Tick marks on the horizontal axis indicate the positions of the microsatellite markers, the vertical axis indicates the NPL score, and the thick line shows the NPL score along each chromosome. Genome-wide thresholds for suggestive and significant linkage were calculated by simulation to be 1.9 and 2.7, respectively (Rioux et al.2000).

To investigate the possibility that the linkage peak at 6p is due to presence of the HLA DQ2 risk alleles, the DQ2 alleles were genotyped. Altogether 91% of the CD patients had at least one copy of the HLA DQ2 risk haplotype, while only 40% of unaffected individuals had one or more copies of the risk haplotype. In addition, the HLA risk haplotype showed a significant association with the CD phenotype (Z score=6.94; $p=1.96 \times 10^{-12}$), indicating that the DQ2 alleles (or other alleles/genotypes in strong linkage disequilibrium with DQ2) contribute to CD susceptibility.

Because the 2q23-32 region contains the *CTLA-4* gene, a gene first reported by Djilali-Saiah et al. (1998) to have the A allele (the +49*A/G dimorphism) associated with CD, all study subjects were genotyped for this variant. Sib-TDT analysis did not provide significant evidence for an association of this allele with CD. However, when our results were combined with three additional follow-up studies, that reported the actual association data for this specific variant (Clot et al. 1999, Naluai et al. 2000, Mora et al. 2003), the combined results from 506 families resulted in a pooled one-tailed p -value of 0.002 and an OR of 1.29 (95% 1.09-1.52), potentially replicating the original finding.

5.2 Gene dose effect of the *DQA10501 allele and the *DQB1**0201 allele on the severity of coeliac disease (Study II)**

Genotype frequencies of the CD risk alleles in patients with CD were as follows: *DQA1**0501; no risk alleles in 8.3% ($n=12$), one risk allele in 72.9% ($n=105$), two risk alleles in 18.8% ($n=27$) of subjects; and *DQB1**0201; no risk alleles in 6.3% ($n=9$), one risk allele in 71.5% ($n=103$), and two risk alleles in 22.2% ($n=32$) of the subjects. These variants were in strong linkage disequilibrium ($D'=0.90$, $p<0.001$). Of all patients, 13.2% ($n=19$) were homozygous for both alleles and 5.6% ($n=8$) had neither of the alleles.

The DQ2 heterodimer frequencies of CD patients were as follows: not present in 9.0% (n=13; no *DQA1*0501* nor *DQB1*0201* allele n=8, only one *DQA1*0501* allele n=1, only one *DQB1*0201* allele n=4), heterozygote in 77.8% (n=112; one *DQA1*0501* and one *DQB1*0201* allele n=91, two *DQA1*0501* alleles and one *DQB1*0201* allele n=8, one *DQA1*0501* allele and two *DQB1*0201* alleles n=13) and homozygote in 13.2% (n=19) of subjects.

A significant gene dose effect of the number of the *DQB1*0201* alleles on the grading of small bowel mucosal villous atrophy at the time of CD diagnosis was found (p=0.011, Figure 7). Similarly, homozygosity for the *DQB1*0201* allele was associated with a slower recovery rate of duodenal villous atrophy after one year therapy with GFD (p=0.041, Figure 8). Furthermore, younger age at the time of CD diagnosis was associated with the gene dose effect of the number of the *DQB1*0201* allele (p=0.036). The age at diagnosis was 53±15, 43±15, and 38±14 years in non-allelic, heterozygous, and homozygous subjects for *DQB1*0201*, respectively. In contrast, the number of the *DQA1*0501* alleles was not associated with villous atrophy or the age at CD diagnosis.

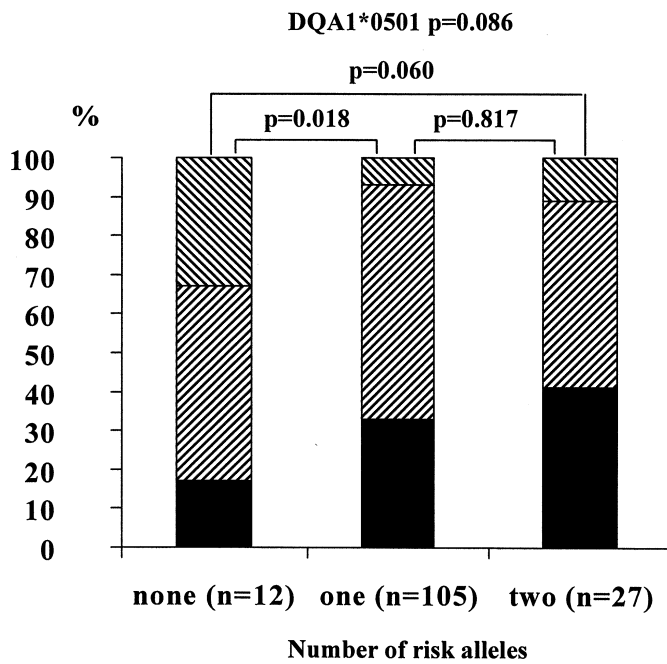
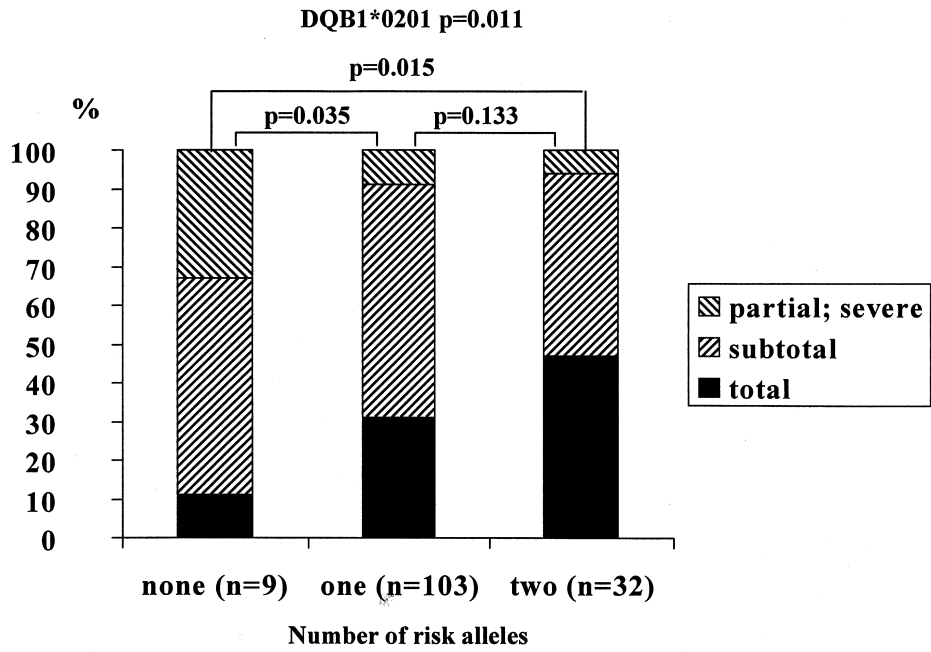

Figure 7. Effect of the *DQB1*0201* and *DQA1*0501* alleles on the grade of small bowel mucosal villous atrophy at the time of diagnosis of CD (II).

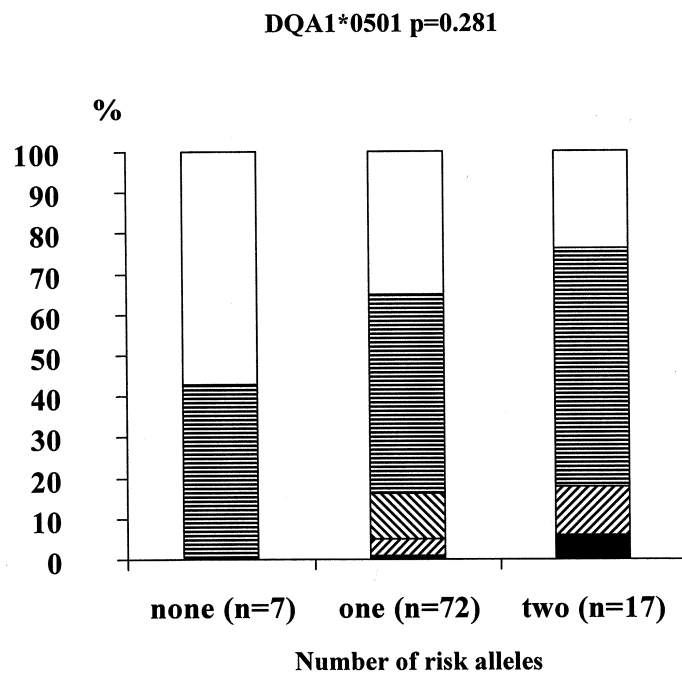
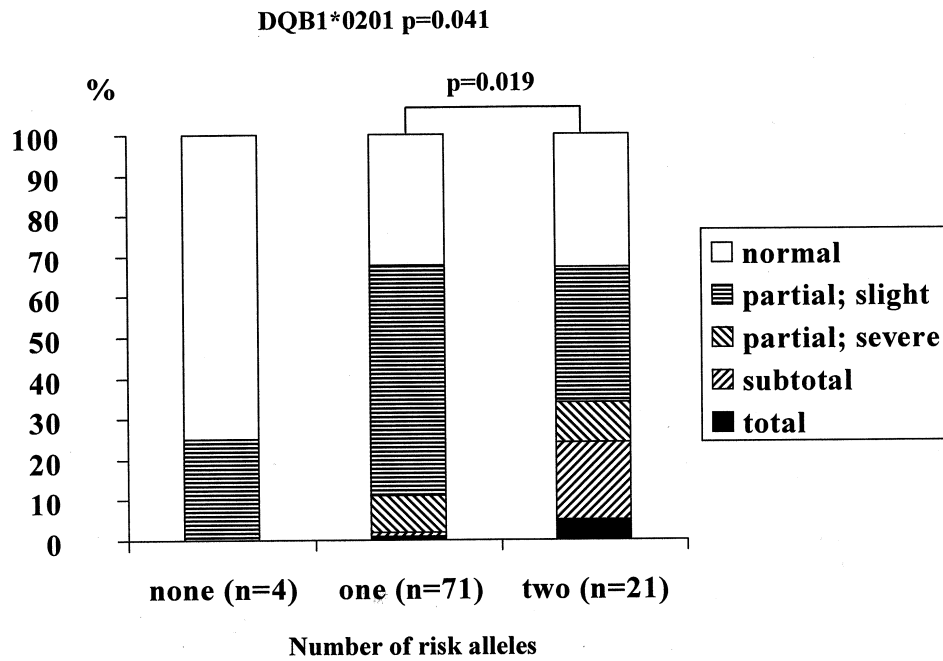

Figure 8. Effect of the *DQB1*0201* and *DQA1*0501* alleles on the grade of villous atrophy after one year on GFD (II).

Furthermore, homozygosity for the *DQB1*0201* allele ($p=0.010$) was associated with lower blood haemoglobin level at the time of diagnosis, even after adjustment for the severity of villous atrophy and gender ($p=0.036$). There were no significant differences in mean cellular volume of erythrocytes, serum iron, folate of erythrocytes, plasma calcium, and serum albumin values among different genotype groups although serum iron and folate of erythrocytes tended to be lower in subjects homozygous for the *DQB1*0201* allele. In addition, homozygosity for the *DQB1*0201* allele was associated with severe abdominal pain ($p=0.015$), severe diarrhoea ($p=0.048$), and with a more frequent stool frequency ($p=0.050$) at the time of CD diagnosis, but the homozygosity for the *DQA1*0501* allele was associated only with severe abdominal pain ($p=0.040$).

Because of the linkage disequilibrium between the *DQA1*0501* and *DQB1*0201* alleles, we next analyzed the effect of the DQ2 heterodimer on the severity of CD. A significant association of homozygosity of the DQ2 heterodimer compared to those without the DQ2 heterodimer was found with a more severe villous atrophy ($p=0.006$) and a lower value of blood haemoglobin ($p=0.015$) at the time of diagnosis. In contrast, the gene dose effect of the DQ2 heterodimer was not associated with the severity of villous atrophy after one year on GFD ($p=0.814$), age at diagnosis ($p=0.207$), stool frequency ($p=0.106$), degree of diarrhoea ($p=0.238$), degree of abdominal pain ($p=0.059$), or level of the other laboratory values than blood haemoglobin.

5.3 HLA genotyping in the evaluation of the risk for coeliac disease in the first-degree relatives (Study III)

Of all first-degree relatives investigated ($n=245$), 17.6% ($n=43$) did not carry any of the CD risk alleles (Table 8). Altogether, 5.9% of the parents of probands, 15.7% of the siblings of

probands, and 25.8% of the offspring of probands did not have any of the CD risk alleles. Of the CD probands (n=54) and the CD affected first-degree relatives (n=82), all except one individual (99.3%) carried at least one of the CD associated alleles *DQA1*0501*, *DQB1*0201*, or *DRB1*04*. Most of the affected first-degree relatives (n=73, 89%) carried both the *DQA1*0501* allele and the *DQB1*0201* allele. Altogether 7.3% (n=6) carried only the *DRB1*04* allele, but not the *DQA1*0501* allele or the *DQB1*0201* allele.

Table 8. The HLA status of the probands with CD (n=54) and their first-degree relatives (n=245) (III).

	no DQAI		DQAI		DQAI		DQAI		no DQAI		no DQAI		Total
	no DQBI	DRBI	DQBI	DRBI	no DQBI	DRBI	no DQBI	DRBI	DQBI	DRBI	no DQBI	DRBI	
Coeliac disease													
Probands	0	4	47	0	0	1	0	0	2	0	0	0	54
Parents of probands	0	0	3	0	0	0	0	0	0	0	2	0	5
Siblings of probands	1*	4	58	0	0	0	0	0	2	4	0	0	69
Offspring of probands	0	0	8	0	0	0	0	0	0	0	0	0	8
No coeliac disease													
Parents of probands	1	0	7	2	2	0	2	0	0	0	0	0	12
Siblings of probands	25	2	40	7	3	3	3	5	5	12	0	0	97
Offspring of probands	16	5	19	1	0	0	5	0	0	8	0	0	54
Altogether	43	15	182	10	4	4	10	9	9	26	26	26	299
Percentage of subjects with coeliac disease in each HLA risk group	2.3	53.3	63.7	0	25.0	0	0	44.4	0	23.1	23.1	23.1	

DQAI=DQAI*0501 allele

DQBI=DQBI*0201 allele

DRBI=DRBI*04 allele

*Moderate partial villous atrophy with positive anti-gliadin antibodies (negative endomysial and anti-reticulin antibodies).

5.4 Combined role of HLA genotyping, serological tests, and symptoms in the screening for coeliac disease among the first-degree relatives (Study IV)

Altogether 45 (21.6 %) of the screened individuals were diagnosed to have CD. Of those first-degree relatives (n=163), who did not have CD, 42 (25.8%) carried none of the HLA alleles associated with CD.

GI symptoms, except for abdominal pain, occurred significantly more frequently in those first-degree relatives who were diagnosed to have CD than in the non-affected relatives (Table 9). However, abdominal complaints were common both in CD patients and in healthy subjects. Furthermore, 14.3 % (n=6) of the subjects with CD reported no GI symptoms, and 14.3 % (n=6) experienced only one of the symptoms. Moreover, 47.6 % (n=20) of affected first-degree relatives with CD, who had more than one of the symptoms, reported only mild symptoms, and none of them had severe symptoms. There was no statistical difference in GI symptoms among non-affected relatives who had the HLA status typical for CD and non-affected relatives who did not have the HLA status typical for CD (Table 9).

Table 9. Gastrointestinal symptoms in the first-degree relatives of patients with CD (IV).

Symptom	Group A	Group B	Group C
	CD; diagnosed by screening n=42 n (%)	No CD; HLA risk alleles for CD ¹ n=110 n (%)	No CD; No HLA risk alleles for CD ² n=37 n (%)
Diarrhoea *			
none	17 (40.5)	85 (77.3)	25 (67.6)
mild	25 (59.5)	21 (19.1)	11 (29.7)
moderate	0 (0)	3 (2.7)	1 (2.7)
severe	0 (0)	1 (0.9)	0 (0)
Abdominal pain			
none	22 (52.4)	70 (63.6)	29 (78.4)
mild	18 (42.9)	38 (34.5)	8 (21.6)
moderate	2 (4.8)	2 (1.8)	0 (0)
severe	0 (0)	0 (0)	0 (0)
Abdominal bloating **			
none	11 (26.2)	51 (46.4)	19 (51.4)
mild	20 (47.6)	51 (46.4)	12 (32.4)
moderate	11 (26.2)	8 (7.3)	6 (16.2)
severe	0 (0)	0 (0)	0 (0)
Flatulence †			
none	7 (16.7)	35 (31.8)	8 (21.6)
mild	21 (50.0)	65 (59.1)	21 (56.8)
moderate	14 (33.0)	10 (9.1)	8 (21.6)
severe	0 (0)	0 (0)	0 (0)

¹ Carries at least one of the following alleles: *DQA1*0501*, *DQB1*0201*, or *DRB1*04*

² Carries none of the following alleles: *DQA1*0501*, *DQB1*0201*, or *DRB1*04*

* p<0.001 between Groups A (= CD) and Groups B+C (= no CD)

** p=0.005 between Groups A (= CD) and Groups B+C (= no CD)

† p=0.004 between Groups A (= CD) and Groups B+C (= no CD)

Table 10. Comparison of different screening strategies for CD in the first-degree relatives (n=189) (IV).

Screening strategy*	EGD	EMA	AGA	EMA and AGA	GI symptoms
Screening test positive n (%) of first-degree relatives	42 (22.2 %)	38 (20.1 %)	87 (46.0 %)	90 (47.6 %)	153 (81.0 %)
CD diagnosed n (% of CD cases)	42 (100 %)	35 (83.3 %)	40 (95.2 %)	41 (97.6 %)	36 (85.7 %)
CD cases missed n (%)	0 (0 %)	7 (16.7 %)	2 (4.8 %)	1 (2.4 %)	6 (14.3 %)
Number of EGD needed	189	38	87	90	153
Number of EGD needed if HLA genotyping done first**	151	38	70	74	116
Number of EGD saved if HLA genotyping done first**	38 (20.1 %)	0 (0 %)	17 (19.5 %)	16 (17.8 %)	37 (24.2 %)
CD cases missed if HLA genotyping done first**	1 (2.4 %)	7 (16.7 %)	3 (7.1 %)	2 (4.8 %)	7 (16.7 %)

*EGD=gastroscopy with duodenal biopsies, EMA=endomysial antibodies, AGA=anti-gliadin antibodies, GI=gastrointestinal

** Figure 9

EMA and ARA were negative in 16.7% (n=7) and 23.8% (n=10) of CD patients, respectively. EMA and ARA were positive in 2.7% (n=3) of the non-affected first-degree relatives; all of whom carried HLA risk alleles for CD. EMA and ARA were negative in most of the non-affected first-degree relatives who had HLA status associated with CD (97.3%). AGA was negative in 4.8% (n=2) of CD patients. AGA was positive in 32.0% (n=47) of non-affected relatives, of whom 16 individuals (34.0%) did not carry any of the HLA risk alleles associated with CD.

The comparison between different screening strategies for CD in the first-degree relatives based on our study results is shown in Table 10. If the HLA risk allele genotyping is done first and if relatives who carry none of the HLA risk alleles associated with CD are excluded from further screenings, the need of EGD is reduced by about 20 %.

6. DISCUSSION

6.1 Subjects and Study design

The advantage of the Finnish population in genetical studies is a relatively homogenous gene pool, originating mainly from Southern (European) and Eastern (Asian) immigration about 2000 years ago (de la Chapelle 1993, Kittles et al. 1998). In addition, the environmental and cultural variability is low when compared to many other populations. When added with high co-operativeness of Finnish subjects with medical research and the high standard of the medical and population based records, the Finnish population has proved to be valuable in genetical studies, especially in finding single gene defects. However, the value of the Finnish population in studies of complex diseases, such as CD, is less clear (Liu et al. 2002). At the time, when our study was started no genome-wide screenings for CD had been published.

Our results might have been biased by the fact that our study population consisted of multi-affected families. The prevalence of CD in the first-degree relatives of our families was 17.6% for all the first-degree relatives (21.5 and 33.5% for all first-degree relatives alive and for the first-degree relatives having duodenal biopsies, respectively) (Table 7). In addition to high prevalence of CD in our families as compared to most previously published family-based studies (Table 1), the genetic background might differ between the families with multiple cases of CD and sporadic cases of CD. The frequency of the HLA alleles associated with CD is probably lower in families with sporadic CD patients than in our study population. The true prevalence of CD in our families remains unclear because 35.9% of the first-degree relatives refused to participate in this study. It is expected that they were less symptomatic than those relatives who participated.

6.2 Methods

Diagnostic criteria for CD

The strict criteria used for the diagnosis of CD in our study lead to a smaller but more homogenous set of affected sib-pairs, thereby increasing the chance of detecting significant linkage in the genome-wide scan. By these strict criteria some relatives with CD were omitted (slight villous atrophy with positive CD antibody tests), although they were clinically treated as CD patients. Altogether 90.3% of CD patients included in the genome-wide scan had total or subtotal villous atrophy at the time of diagnosis. After one year on GFD 84.3% had normal villous structure or slight villous atrophy thus confirming the diagnosis of CD and reflecting good adherence to GFD by most of the CD patients.

Antibody testing

The results of the CD antibody testing showed that EMA and ARA were negative in 16.7% and 23.8%, respectively, of patients found to have CD in our families). AGA was more sensitive, but unspecific, partly because of the threshold of AGA positivity which was low in the laboratory we used. EMA, ARA, and AGA measurements were done in the same laboratory, which should have high quality of CD antibody tests. However, sensitivity and specificity of the serological tests have been variable also in previous studies (Hill 2005). In some studies, serological tests have been negative in patients with partial villous atrophy (Rostami et al. 2000, Abrams et al. 2004), whereas in a Finnish study EMA was negative in the case of advanced CD (Salmi et al. 2006b). The possibility of the IgA-deficiency of our study subjects was ruled out by determining S-IgA level from all the study subjects. In addition, IgG-AGA was measured from all the study subjects. tTG antibody test was not performed because the method was not available at the time when our study was started.

Assessment of symptoms

The lack of validated assessment of symptoms of CD makes it difficult to assess the value of a symptom questionnaire. In our study, the questionnaire was completed prospectively before the histology of biopsies was known. CD patients who had been diagnosed before our study had significantly more often GI symptoms than those CD patients who were diagnosed to have CD in the present study (data not shown). Also CD patients, who were diagnosed in our study, had significantly more symptoms than relatives who did not have CD. However, GI symptoms occurred frequently also in non-affected relatives. These findings imply that the use of GI symptoms as a tool to diagnose CD has a limited value.

6.3 Genetics of coeliac disease (Study I)

In our genome-wide scan two gene regions (6p and 2q23-32) had a significant association with CD, and one gene region (10p) had a possible association. Based on twin and family studies, CD had an obvious genetic background but the previously known HLA genes were estimated to account for less than 50% of the genetic component of CD (Petronzelli et al. 1997, Bevan et al. 1999b). The assessment of susceptibility genes for CD is likely to clarify the pathogenesis of CD and give new possibilities for the diagnosis and therapy of CD.

The strongest association peak was found in the HLA region on chromosome 6p. This HLA association could be explained by the association with the DQ2 haplotype in agreement with several previous studies (Table 3).

The significant association with the region 2q23-32 was interesting, because in many candidate gene studies for CD the association with the genes *CTLA-4* and/or *CD 28* in this region has been proposed (Table 4) and both the *CTLA-4* and the *CD28* genes are involved in

T cell activation and proliferation. Furthermore, the *CTLA-4* gene has been associated with other autoimmunity diseases (Zhernakova et al. 2005). The results of the candidate gene studies have, however, been conflicting (Table 4). It is possible that another gene in the vicinity of the *CTLA-4* or the *CD 28* genes is responsible for the association (King et al. 2002). In our original study population, the association with the *CTLA-4* gene was not found. When our results were pooled with three previous studies (Clot et al. 1999, Naluai et al. 2000, Mora et al. 2003), combined results indicated a significant association with the *CTLA-4* gene. These combined results may be biased by previous negative results. Three previous negative studies for an association of the *CTLA-4* +49*A/G with CD were not included since they did not report the raw data for the variant determined (+49*A/G), or had genotyped genetic markers nearby (Holopainen et al. 1999, King et al. 2002, Popat et al. 2002d).

Our genome-wide scan identified a possible CD susceptibility locus on chromosome 10p. The same region showed a nominal significance also in a genome-wide scan in North American families (Neuhausen et al. 2002). Thus far, promising candidate genes for CD in this region have not been published. Additional markers and additional families are needed to determine the importance of this locus.

There are several reasons for conflicting results between genome-wide scans in different populations (Table 3). The lack of replication of original linkage study results is a common problem in complex diseases, partially related to low power of studies to detect genes of relatively small effect and/or to a high degree of genetic heterogeneity among families (Risch et al. 1996, Bevan et al. 1999b, Sollid et al. 2005b). Larger data sets with more statistical power are needed to confirm the linkage. Single-nucleotide polymorphism -method, which

has not been applied in genome-wide screenings for CD, might provide new possibilities to identify genes predisposing for CD.

6.4 Role of the HLA alleles *DQA1*0501* and *DQB1*0201* in coeliac disease (Studies II and IV)

Our study was the first one aiming to investigate the association of the *DQA1*0501* and *DQB1*0201* alleles with different degrees of villous atrophy at the time of diagnosis of CD, and after one year on GFD. In a previous study on paediatric CD patients, in whom a crude grading of villous atrophy as “subtotal or non-subtotal” and “typical or atypical” was used, no association between the gene-dose effect of either the HLA DQ2 haplotype or the *DQB1*0201* allele and CD was found (Zubillaga et al. 2002). Based on our results, it is likely that the carriers of the two *DQB1*0201* alleles have more severe villous atrophy and are more resistant to GFD. In addition, refractory CD seems to be associated with the homozygosity of the HLA DQ2 haplotype (Al-Toma et al. 2006).

Our study was the first one to investigate the contribution of the number of the *DQA1*0501* and *DQB1*0201* alleles on laboratory parameters reflecting the nutritional status. At diagnosis, haemoglobin level was significantly lower in subjects who were homozygous for the *DQB1*0201* allele compared to other subjects, even after the adjustment for gender and the degree of villous atrophy. Thus, the homozygosity for *DQB1*0201* could be associated with villous atrophy, extending more distally in the small intestine. Moreover, also serum iron and folate of erythrocytes tended to be lower in subjects homozygous for the *DQB1*0201* allele. The absorption of iron and folate occurs in the proximal part of small intestine, a region most often and most seriously affected in CD.

In our study the age at diagnosis was significantly lower in carriers who were homozygous for the *DQB1*0201* allele than in patients without the *DQB1*0201* alleles. In previous studies the results have been conflicting (Table 2). In a large Italian study, where also the frequency of the *DQB1*0201* allele was determined, a trend towards a younger age at diagnosis was found in homozygous carriers of the *DQB1*0201* allele (Greco et al. 1998b). In contrast, in a Norwegian study a significant correlation of the homozygosity for the *DQB1*0201* allele with later onset of CD was found. However, the Norwegian study included only paediatric patients who were arbitrarily divided into two groups of early and late onset of CD (Ploski et al. 1993). Taken together, based on our study and a previous Italian study (Greco et al. 1998b), the presence of the two *DQB1*0201* alleles seems to be associated with low age at diagnosis of CD.

The assessment of the effect of the dose of the *DQA1*0501* and *DQB1*0201* alleles on symptoms of CD is unreliable because of the lack of a validated clinical assessment. According to our results the homozygosity of the *DQB1*0201* allele was associated with severe abdominal pain, severe diarrhoea, and with a more frequent stools at the time of CD diagnosis. In previous studies, the results concerning the symptoms and the gene-dose effect have been controversial (Table 2). Other genes than HLA, the amount of gluten intake (Carlsson et al. 2006), and behavioural aspects might influence the frequency of symptoms reported. GI symptoms were common in non-affected relatives regardless of their HLA status (Study IV; Table 9).

Strong association of CD with the HLA DQ2 haplotype has been previously published (Sollid et al. 1989, Sollid et al. 1990, Tighe et al. 1992, Congia et al. 1992, Louka et al. 2003, Karell et al. 2003). One of the *DQA1*0501* or *DQB1*0201* alleles encoding the HLA-DQ2

heterodimer, appears to be sufficient for conferring susceptibility to CD (Sollid et al. 1993, Karell et al. 2003). However, in several studies, including our study, the risk for CD has been significantly greater in subjects homozygous for the DQ2 haplotype or the *DQB1*0201* allele than in subjects heterozygous for this haplotype or allele or in subjects without these alleles (Table 2). The HLA DQ2 molecules, which are formed by different number of *DQA1*05* and *DQB1*02* alleles, might bind with different affinity to the peptides derived from gluten and modified by enzymes, especially the tTG enzyme. Furthermore, the magnitude of the T-cell reaction, which appears to be a consequence of the peptide binding with the HLA DQ2 molecule, is influenced by the number of the *DQA1*05* and the *DQB1*02* alleles (Vader et al. 2003). These new pathogenic data also support our results of the gene-dose effects of the *DQB1*0201* allele on the severity of CD.

6.5 Screening for coeliac disease in families (Studies II, III and IV)

Our study was the first one to confirm that the HLA genotyping could be used to exclude a part of the first-degree relatives (about 20%) from further CD screening (Study III). In offspring of CD patients, even more subjects could be excluded (over 25%). Thus, the HLA genotyping is particularly useful in the offspring of CD patients because they have longer life-time expectancy than siblings of CD patients. Furthermore, the HLA genotyping is probably beneficial also in sporadic CD cases, because the frequency of the HLA-associated risk alleles is expected to be lower among first-degree relatives than in our families which were multi-affected with CD. All HLA alleles (*DQA1*0501*, *DQB1*0201*, and *DRB1*04*) should be determined regardless of the HLA status of the index patient in a family (Study III; Table 8). It is possible that by genotyping the *DQB1*0302* allele, which encodes the DQ8 heterodimer, instead of the *DRB1*04* allele even more family members could have been excluded from further screenings.

Which is the best screening method for the first-degree relatives who carry the HLA-associated risk alleles remains unclear. Because of the relatively high risk of CD in families, heterogeneity of the symptoms (Study IV), and the complications of untreated CD, the screening for CD in families has been recommended although the natural history and the prognosis of asymptomatic CD remain largely unknown (Collin 2005, Cranney et al. 2005, Hoffenberg 2005). Based on our study population (Study III and IV), the screening by EMA would lead to missing of almost 20% of the relatives having CD. The sensitivity and specificity of serological tests have been variable also in previous studies (Rostami et al. 1999, Dickey et al. 2000, Tursi et al. 2001, Abrams et al. 2004, Salmi et al. 2006b). When AGA was determined in addition to EMA, the percentage of missed CD cases was lower on the cost of lower specificity and increased number of EGDs (Table 10). Even EGD can miss cases of CD if the quality of small bowel mucosal biopsies is not good, lesions of CD are patchy, or the pathologist is not experienced to diagnose CD (Dewar et al. 2005). In addition, EGD as a screening test is an invasive and also expensive procedure even in a high-risk group. Recently, tTG antibody test has proven to be at least as good in sensitivity and specificity than is EMA, and it is easier and cheaper to perform (Collin 2005, Hill 2005). In future, the deamidated gliadin peptide antibody test might provide a new screening method for CD with high sensitivity and specificity (Kaukinen et al. 2007).

Because of the lifetime risk of CD the timing of CD screening is difficult. Relatives who have positive EMA (or ARA), but no villous atrophy on duodenal biopsies, should be screened further by EGD, because they are at risk to develop CD in future (Mäki et al 1991, Collin et al. 1993, Högberg et al. 2003, Salmi et al. 2006). The other relatives could be further screened with EMA (or alternatively tTG-antibodies), because of the high risk of CD in families for

example with 5-year intervals (Goldberg et al. 2007). Based on our results, AGA would increase the sensitivity of screening but generally AGA is not recommended for screening because of its low specificity (Collin 2005). The relatives who are homozygous for the *DQB1*0201* allele should probably be screened more frequently (Study II). EGD should be performed on all relatives with clinical suspicion of CD (GI symptoms, abnormal nutritional laboratory parameters, atypical symptoms) regardless of the CD antibody status. EGD is the most sensitive and specific screening method for CD (Study IV), but as it is an invasive and expensive procedure it is not feasible to screen all relatives by this method.

In Figure 9, an algorithm for a screening procedure of CD in the first-degree relatives is suggested based on our results. First, genotyping of the HLA risk alleles *DQA1*0501*, *DQB1*0201*, and *DRB1*04* (or *DQB1*0302*) should be performed. All relatives carrying any of the HLA risk alleles should be further screened for CD with EMA (or alternatively tTG) and possibly AGA. IgG-antibodies should be used in case of selective IgA-deficiency. If antibody tests are positive or any symptoms related to CD exist, EGD should be performed. The antibody screening should be performed repeatedly because of the lifetime risk of CD.

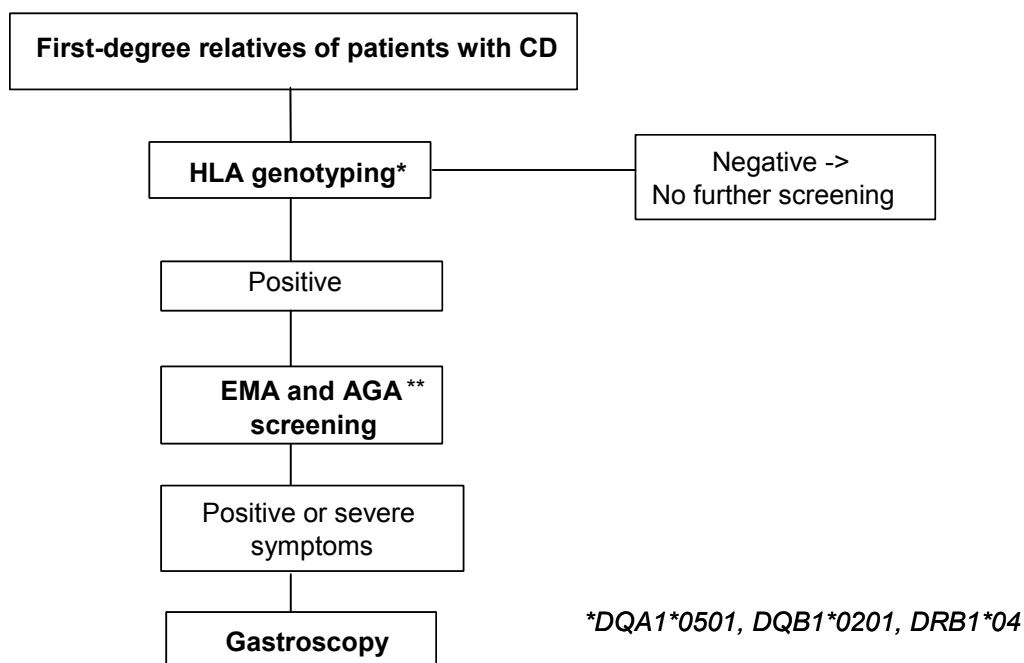

Figure 9. Algorithm for screening for CD in the first-degree relatives (IV).

** Current guidelines recommend not to use AGA in the screening of CD.

6.6 Concluding remarks

In this study of 54 Finnish families with CD, a genome-wide scan was performed to identify susceptibility loci for CD. In addition, the genotype and phenotype correlations of CD were investigated, and different screening methods for CD in the first-degree relatives were tested. CD develops as a result of an interaction between genetic, environmental, and immunological factors.

Three loci which associate with CD were found (6p, 2q23-32, 10p) in our genome-wide scan. The 2q23-32 region is of special interest, because it is associated with CD also in candidate

gene studies and includes genes involved in the T-cell activity. The 6p region includes the previously known and confirmed HLA region, whereas the 10p region does not involve any genes proposed for CD so far. The limitation of genome-wide scans in complex diseases is a low power to detect genes of minor effect (Risch et al. 1996; Bevan et al. 1999b). The results of genome-wide scans have varied in different populations. In the future, genome-wide scan using single nucleotide polymorphisms covering the entire genome should be performed. Knowledge on the genetic background of CD could clarify the pathogenesis of CD and give new strategies for diagnosing, screening, and treatment of CD. Furthermore, CD could provide a model for understanding other autoimmune diseases, because it is an autoimmune disease where the interaction between environmental factors (gluten-related proteins) and other parts of the pathogenesis are quite well understood.

Better knowledge of the genetic background of CD would also help us to understand different phenotypes of CD. In our study, the dose of the *DQB1*0201* allele seems to contribute to the severity of CD assessed by the degree of villous atrophy, laboratory parameters, age, and GI symptoms at the CD diagnosis, whereas the dose of the *DQA1*0501* allele did not have such an effect. It is likely, that also environmental factors, such as amount of gluten intake, contribute to the clinical features of CD.

Because of the heterogeneity of the symptoms of CD and the life-time risk for CD in genetically disposed individuals, screening for CD in families is challenging. By using the HLA allele genotyping, a part of the relatives could be excluded from further screenings. The rest of the relatives should be further screened for CD. The problem of the serological screening is varying sensitivity and specificity of different CD antibodies, as well as the fact that it reflects only the status of CD at the moment the screening is done and not the risk of

CD in future. Resolution of the genetics of CD might give new tools also for screening. Cost-effectiveness of different screening strategies in families and a possible mental burden caused to relatives by HLA genotyping need to be studied.

7. SUMMARY

In this study of 54 Finnish families with CD, the genetic background of CD and phenotype differences associated with the genetic background were investigated. In addition, screening methods for the first-degree relatives of CD probands were investigated with a special interest on the HLA genotyping as an initial test.

Study I: In a genome-wide scan a significant association with the chromosomal region 6p and 2q23-32 and a suggestive association with the region 10p were found. In addition, an association of the *CTLA-4* gene which is located within the region 2q23-32 with CD was observed.

Study II: The gene-dose effect of the HLA *DQB1*0201* allele, but not of the *DQA1*0501* allele, was found to contribute to the severity of CD assessed by the grade of villous atrophy at diagnosis and after one year on therapy, blood haemoglobin level, age, and GI symptoms at diagnosis.

Study III: Genotyping for the HLA alleles *DQA1*0501*, *DQB1*0201*, and *DRB1*04* was found to be useful in excluding about 20% of the first-degree relatives from further screening for CD. The benefit was greatest in the offspring of the CD probands.

Study IV: GI symptoms were frequent, but mostly mild or even totally lacking, in the first-degree relatives who were found to have CD by screening. EMA was negative in 16.7% of the affected relatives. AGA was more sensitive, but unspecific. An algorithm based on an initial HLA genotyping for the screening of CD in the first-degree relatives was suggested.

8. REFERENCES

- Abrams JA, Diamond B, Rotterdam H, Green PH. Seronegative celiac disease: increased prevalence with lesser degrees of villous atrophy. *Dig Dis Sci* 2004;49:546-50.
- Aldersley MA, Hamlin PJ, Jones PF, Markham AF, Robinson PA, Howdie PD. No polymorphism in the tissue transglutaminase gene detected in coeliac disease patients. *Scand J Gastroenterol* 2000;35:61-3.
- Al-Toma A, Goerres MS, Meijer JW, Pena AS, Crusius JB, Mulder CJ. Human leukocyte antigen-DQ2 homozygosity and the development of refractory celiac disease and enteropathy-associated T-cell lymphoma. *Clin Gastroenterol Hepatol* 2006;4:315-9.
- Amundsen SS, Naluai AT, Ascher H, et al. Genetic analysis of the CD28/CTLA4/ICOS (CELIAC 3) region in coeliac disease. *Tissue Antigens* 2004;64:593-9.
- Amundsen SS, Monsuur AJ, Wapenaar MC, et al. Association analysis of MYO9B gene polymorphisms with celiac disease in a Swedish/Norwegian cohort. *Hum Immunol* 2006;67:341-5.
- Arai T, Michalski JP, McCombs CC, Elston RC, McCarthy CF, Stevens FM. T cell receptor gamma gene polymorphisms and class II human lymphocyte antigen genotypes in patients with celiac disease from the West of Ireland. *Am J Med Sci* 1995;309:171-8.
- Arentz-Hansen H, McAdam SN, Molberg O, et al. Celiac lesion T cells recognize epitopes that cluster in regions of gliadins rich in proline residues. *Gastroenterology* 2002;123:803-9.
- Arranz E, Telleria JJ, Sanz A, et al. HLA-DQA1*0501 and DQB1*02 homozygosity and disease susceptibility in Spanish coeliac patients. *Exp Clin Immunogenet* 1997;14:286-90.
- Auricchio S, Mazzacca R, Tosi R, Visakorpi J, Mäki M, Polanco I. Coeliac disease as a familial condition: Identification of asymptomatic coeliac patients within family groups. *Gastroenterol Internat* 1988;1:25-31.
- Babron MC, Nilsson S, Adamovic S, et al. Meta and pooled analysis of European coeliac disease data. *Eur J Hum Genet* 2003;11:828-34.
- Balas A, Vicario JL, Zambrano A, Acuña D, Garcia-Novo D. Absolute linkage of celiac disease and dermatitis herpetiformis to HLA-DQ. *Tissue Antigens* 1997;50:52-6.
- Barisani D, Ceroni S, Meneveri R, Cesana BM, Bardella MT. IL-10 polymorphisms are associated with early-onset celiac disease and severe mucosal damage in patients of Caucasian origin. *Genet Med* 2006;8:169-74.
- Barone MV, Caputo I, Ribocco MT, et al. Humoral immune response to tissue transglutaminase is related to epithelial cell proliferation in celiac disease. *Gastroenterology* 2007;132:1245-53.
- Bevan S, Popat S, Braegger CP, et al. Contribution of the MHC region to the familial risk of coeliac disease. *J Med Genet* 1999a;36:687-90.

Bevan S, Popat S, Houlston RS. Relative power of linkage and transmission disequilibrium test strategies to detect non-HLA linked coeliac disease susceptibility genes. *Gut* 1999b;45:668-71.

Bilbao JR, Martin-Pagola A, Vitoria JC, Zubillaga P, Ortiz L, Castano L. HLA-DRB1 and MHC class 1 chain-related A haplotypes in Basque families with celiac disease. *Tissue Antigens* 2002;60:71.

Bjornvold M, Amundsen SS, Stene LC, et al. *FOXP3* polymorphisms in type 1 diabetes and coeliac disease. *J Autoimmun* 2006;27:140-4.

Boniotto M, Braidà L, Ventura A, Percopo S, Amoroso A, Crovella S. Promoter polymorphisms of the CD14 gene in Italian patients with coeliac disease. *J Med Genet* 2003;40:e108.

Bottaro G, Cataldo F, Rotolo N, Spina M, Corazza GR. The clinical pattern of subclinical/silent celiac disease: an analysis on 1026 consecutive cases. *Am J Gastroenterol* 1999;94:691-6.

Bradbury P, Gordon KC. Connective tissues and stains. In: Bancroft JD, Stevens A, editors. *Theory and practise of histological techniques*. Edinburgh, London, Melbourne and New York: Churchill Livingstone; 1982. pp 133-4.

Brett PM, Yiannakou JY, Morris M-A, et al. A pedigree-based linkage study of coeliac disease: failure to replicate previous positive findings. *Ann Hum Genet* 1998;62:25-32.

Brophy K, Ryan AW, Thornton JM, et al. Haplotypes in the CTLA-4 region are associated with coeliac disease in the Irish population. *Genes Immun* 2006;7:19-26.

Carlsson A, Agardh D, Borulf S, Grodzinsky E, Axelsson I, Ivarsson SA. Prevalence of celiac disease: before and after a national change in feeding recommendations. *Scand J Gastroenterol* 2006;41:553-8.

Cataldo F, Lio D, Marino V, et al. Cytokine genotyping (TNF and IL-10) in patients with celiac disease and selective IgA deficiency. *Am J Gastroenterol* 2003;98:850-6.

Catassi C, Bearzi I, Holmes GKT. Association of celiac disease and intestinal lymphomas and other cancers. *Gastroenterology* 2005;128:S79-S86.

Cellier C, Patey N, Mauvieux L, et al. Abnormal intestinal intraepithelial lymphocytes in refractory sprue. *Gastroenterology* 1998;114:471-81.

Cellier C, Delabesse E, Helmer C, et al. Refractory sprue, coeliac disease, and enteropathy-associated T-cell lymphoma. French Coeliac Disease Study Group. *Lancet* 2000;356:203-8.

Cirillo G, Di Domenico MR, Corsi I, et al. Do MYO9B genetic variants predispose to coeliac disease? An association study in a cohort of South Italian children. *Dig Liver Dis* 2007; 39:228-31.

Clay TM, Culpan D, Pursall MC, Bradley BA, Bidwell JL. HLA-DQB1 and DQA1 matching by ambient temperature PCR-SSCP. *Eur J Immunogenet* 1995;22:467-78.

Clemente MG, De Virgiliis S, Kang JS, et al. Early effects of gliadin on enterocyte intracellular signalling involved in intestinal barrier function. *Gut* 2003;52:218-23.

Clot F, Fulchignoni-Lataud MC, Renoux C, et al. Linkage and association study of the CTLA-4 region in coeliac disease for Italian and Tunisian populations. *Tissue Antigens* 1999;54:527-30.

Collin P, Helin H, Mäki M, Hällström O, Karvonen AL. Follow-up of patients positive in reticulín and gliadin antibody tests with normal small-bowel biopsy findings. *Scand J Gastroenterol* 1993;28:595-8.

Collin P, Pukkala E, Reunala T. Malignancy and survival in dermatitis herpetiformis: a comparison with coeliac disease. *Gut* 1996;38:528-30.

Collin P, Reunala T, Rasmussen M, et al. High incidence and prevalence of adult coeliac disease. Augmented diagnostic approach. *Scand J Gastroenterol* 1997;32:1129-33.

Collin P. New diagnostic findings in coeliac disease. *Ann Med* 1999;31:399-405.

Collin P, Kaukinen K, Välimäki M, Salmi J. Endocrinological disorders and celiac disease. *Endocr Rev* 2002;23:464-83.

Collin P, Rasmussen M, Kyrönpalo S, Laippala P, Kaukinen K. The hunt for coeliac disease in primary care. *Q J Med* 2002;95:75-7.

Collin P, Thorell L, Kaukinen K, Mäki M. The safe threshold for gluten contamination in gluten-free products. Can trace amounts be accepted in the treatment of coeliac disease? *Aliment Pharmacol Ther* 2004;19:1277-83.

Collin P. Should adults be screened for coeliac disease? What are the benefits and harms of screening? *Gastroenterology* 2005;128:S104-8.

Congia M, Frau F, Lampis R. A high frequency of the A30, B18, DR3, DRw52, DQw2 extended haplotype in Sardinian celiac disease patients: further evidence that disease susceptibility is conferred by DQA1*0501, B1*0201. *Tissue Antigens* 1992;39:78-83.

Congia M, Cucca F, Frau F, et al. A gene dosage effect of the DQA1*0501/DQB1*0201 allelic combination influences the clinical heterogeneity of coeliac disease. *Hum Immunol* 1994;40:138-142.

Corrao G, Corazza GR, Bagnardi V, et al. Mortality in patients with coeliac disease and their relatives: a cohort study. *Lancet* 2001;358:356-61.

Cottone M, Termini A, Oliva L, et al. Mortality and causes of death in celiac disease in Mediterranean area. *Dig Dis Sci* 1999;44:2538-41.

Cranney A, Rostom A, Sy R, et al. Consequence of testing for coeliac disease. *Gastroenterology* 2005;128:S109-20.

Csizmadia CG, Mearin ML, Oren A, et al. Accuracy and cost-effectiveness of a new strategy to screen for coeliac disease in children with Down syndrome. *J Pediatr* 2000;137:756-61.

Curley CR, Monsuur AJ, Wapenaar MC, Rioux JD, Wijmenga C. A functional candidate screen for coeliac disease genes. *Eur J Hum Genet* 2006;14:1215-22.

de la Chapelle A. Disease gene mapping in isolated human populations: the example of Finland. *J Med Genet* 1993;30:857-65.

de la Concha EG, Fernandez-Arquero M, Vigil P, et al. Celiac disease and TNF promoter polymorphisms. *Hum Immunol* 2000;61:513-7.

Dewar DH, Ciclitira PJ. Clinical features and diagnosis of coeliac disease. *Gastroenterology* 2005;128:S19-24.

Dicke WK. Coeliakie. MD thesis. University of Utrecht. 1950

Dickey W, Bodkin S. Prospective study of body mass index of patients with coeliac disease. *BMJ* 1998;317:1290.

Dickey W, Hughes DF, McMillan SA. Reliance on serum endomysial antibody testing underestimates the true prevalence of coeliac disease by one fifth. *Scand J Gastroenterol* 2000;35:181-3.

Dickey W, Hughes D. Disappointing sensitivity of endoscopic markers for villous atrophy in a high-risk population: implications for celiac disease diagnosis during routine endoscopy. *Am J Gastroenterol* 2001;96:2126-8.

Dieterich W, Ehnis T, Bauer M, et al. Identification of tissue transglutaminase as the autoantigen of celiac disease. *Nat Med* 1997;3:797-801.

Dieterich W, Laag E, Schopper H, et al. Autoantibodies to tissue transglutaminase as predictors of celiac disease. *Gastroenterology* 1998;115:1317-21.

Diosdado B, Stepniak DT, Monsuur AJ, et al. No genetic association of the human prolyl endopeptidase gene in the Dutch celiac disease population. *Am J Physiol Gastrointest Liver Physiol* 2005;289:G495-500.

Diosdado B, Monsuur AJ, Mearin ML, Mulder C, Wijmenga C. The downstream modulator of interferon-gamma, STAT1 is not genetically associated to the Dutch coeliac disease population. *Eur J Hum Genet* 2006;14:1120-4.

Di Sabatino A, Ciccocioppo R, Cupelli F, et al. Epithelium derived interleukin 15 regulates intraepithelial lymphocyte Th1 cytokine production, cytotoxicity, and survival in coeliac disease. *Gut* 2006;55:469-77.

- Djilali-Saiah I, Schmitz J, Harfouch-Hammond E, et al. CTLA-4 gene polymorphism is associated with predisposition to coeliac disease. *Gut* 1998;43:187-9.
- Dubé C, Rostom A, Sy R, et al. The prevalence of celiac disease in average-risk and at-risk Western European populations: a systematic review. *Gastroenterology* 2005;128:S57-67.
- Dubovsky J, Sheffield VC, Duyk GM, Weber JL. Sets of short tandem repeat polymorphisms for efficient linkage screening of the human genome. *Hum Mol Genet* 1995;4:449-52.
- Ek J, Albrechtsen D, Solheim BG, Thorsby E. Strong association between the HLA-Dw3-related B cell alloantigen-DRw3 and coeliac disease. *Tissue Antigens* 1978;13:229-33.
- Ellis A. Coeliac disease: previous family studies. In: McConnell RB, editor. *The genetics of coeliac disease*. Lancaster, England: MTP;1981. pp 197-200.
- Falchuk ZM, Rogentine GN, Strober W. Predominance of histocompatibility antigen HL-A8 in patients with gluten-sensitive enteropathy. *J Clin Invest* 1972;51:1602-5.
- Fasano A, Berti I, Gerarduzzi T, et al. Prevalence of celiac disease in at-risk and not-at-risk groups in the United States: a large multi-center study. *Arch Intern Med* 2003;163:286-92.
- Fernandez-Arquero M, Figueredo MA, Maluenda C, de la Concha EG. HLA-linked genes acting as additive susceptibility factors in celiac disease. *Hum Immunol* 1995;42:295-300.
- Fernandez L, Fernandez-Arquero M, Gual L, et al. Triplet repeat polymorphism in the transmembrane region of the MICA gene in celiac disease. *Tissue Antigens* 2002;59:219-22.
- Fry L, McMinn RM, Cowan JD, Hoffbrand AV. Gluten-free diet and reintroduction of gluten in dermatitis herpetiformis. *Arch Dermatol* 1969;100:129-35.
- Garrote J, Arranz E, Telleria J, Castro J, Calvo C, Blanco-Quiros A. TNF α and LT α gene polymorphisms as additional markers of celiac disease susceptibility in a DQ2 positive population. *Immunogenetics* 2002;54:551-5.
- Garner CP, Ding YC, Steele L, et al. Genome-wide linkage analysis of 160 North American families with celiac disease. *Genes Immun* 2007;8:108-14.
- Gass J, Bethune MT, Siegel M, Spencer A, Khosla C. Combination enzyme therapy for gastric digestion of dietary gluten in patients with celiac sprue. *Gastroenterology* 2007;133:472-80.
- Gee S. On the coeliac disease. *St Bart Hosp Rep* 1888;24:17-20.
- George VT, Elston RC. Testing the association between polymorphic markers and quantitative traits in pedigrees. *Genet Epidemiol* 1987;4:193-201.
- Gianfrani C, Siciliano RA, Facchiano AM, et al. Transamidation of wheat flour inhibits the response to gliadin of intestinal T cells in celiac disease. *Gastroenterology* 2007;133:780-89.

- Giordano M, Marano C, Mellai M, et al. A family-based study does not confirm the association of MYO9B with celiac disease in the Italian population. *Genes Immunol* 2006;7:606-8.
- Goldberg D, Kryszak D, Fasano A, Green PH. Screening for celiac disease in family members: is follow-up testing necessary? *Dig Dis Sci* 2007;52:1082-6.
- Gonzalez S, Rodrigo L, Lopez-Vazquez A, et al. Association of MHC Class I related gene B (MICB) to celiac disease. *Am J Gastroenterol* 2004;99: 676-80.
- Greco L. Epidemiology of coeliac disease. In: Mäki M, Collin P, Visakorpi JK; editors. *Coeliac disease, Proceedings of the International Symposium on Coeliac disease*. Tampere, Finland: Institute of Medical Technology, University of Tampere; 1997. pp 9-14.
- Greco L, Corazza G, Babron M-C, et al. Genome search in celiac disease. *Am J Hum Genet* 1998a;62:669-75.
- Greco L, Percopo S, Clot F, et al. Lack of correlation between genotype and phenotype in celiac disease. *J Pediatr Gastroenterol Nutr* 1998b;26:286-90.
- Greco L, Babron MC, Corazza GR, et al. Existence of a genetic risk factor on chromosome 5q in Italian coeliac disease families. *Ann Hum Genet* 2001;65:35-41.
- Greco L, Romino R, Coto I, et al. The first large population based twin study of coeliac disease. *Gut* 2002;50:624-28.
- Grillo R, Petronzelli F, Mora B, Bonamico M, Mazzilli MC. Search for coeliac disease susceptibility loci on 7q11.23 candidate region: absence of association with the ELN17 microsatellite marker. *Hum Hered* 2000;50:180-3.
- Hadithi M, von Blomberg BM, Crusius JB, et al. Accuracy of serological tests and HLA-DQ typing for diagnosing celiac disease. *Ann Intern Med* 2007;147:294-302.
- Hahn-Zoric M, Hytönen AM, Hanson LA, Nilsson LA, Padyukov L. Association of -1087 IL-10 and -308 TNFA gene polymorphisms with serological markers of coeliac disease. *J Clin Immunol* 2003;23:291-6.
- Haimila K, Smedberg T, Mustalahti K, Mäki M, Partanen J, Holopainen P. Genetic association of coeliac disease susceptibility to polymorphisms in the ICOS gene on chromosome 2q33. *Genes Immun* 2004;5:85-92.
- Hall MA, Lanchbury JS, Bolsover WJ, Welsh KI, Ciclitira PJ. HLA association with dermatitis herpetiformis is accounted for by a cis and trans associated DQ heterodimer. *Gut* 1991;32:487-90.
- Halttunen T, Mäki M. Serum immunoglobulin A from patients with celiac disease inhibits human T84 intestinal crypt epithelial cell differentiation. *Gastroenterology* 1999;116:566-72.

- Hervonen K, Karell K, Holopainen P, Collin P, Partanen J, Reunala T. Concordance of dermatitis herpetiformis and celiac disease in monozygous twins. *J Invest Dermatol* 2000;115:990-3.
- Hervonen K, Hakanen M, Kaukinen K, Collin P, Reunala T. First-degree relatives are frequently affected in coeliac disease and dermatitis herpetiformis. *Scand J Gastroenterol* 2002;37:51-5.
- Hischenhuber C, Crevel R, Jarry B, et al. Review article: safe amounts of gluten for patients with wheat allergy or coeliac disease. *Aliment Pharmacol Ther* 2006;23:559-75.
- Hill ID. What are the sensitivity and specificity of serologic tests for coeliac disease? Do sensitivity and specificity vary in different populations? *Gastroenterology* 2005;128:S25-32.
- Hoffenberg EJ. Should all children be screened for celiac disease? *Gastroenterology* 2005;128:S98-103.
- Holm K, Mäki M, Savilahti E, Lipsanen V, Laippala P, Koskimies S. Intraepithelial $\gamma\delta$ T-cell-receptor lymphocytes and genetic susceptibility to coeliac disease. *Lancet* 1992;339:1500-3.
- Holopainen P, Arvas M, Sistonen P, et al. CD28/CTLA4 gene region on chromosome 2q33 confers genetic susceptibility to coeliac disease. A linkage and family-based association study. *Tissue Antigens* 1999;53:470-5.
- Holopainen P, Mustalahti K, Uimari P, Collin P, Mäki M, Partanen J. Candidate gene regions and genetic heterogeneity in gluten sensitivity. *Gut* 2001;48:696-701.
- Holopainen P, Naluai AT, Moodie S, et al. Candidate gene region 2q33 in European families with coeliac disease. *Tissue Antigens* 2004;63:212-22.
- Houlston RS, Tomlinson IPM, Ford D, et al. Linkage analysis of candidate regions for coeliac disease genes. *Hum Mol Genet* 1997;6:1335-9.
- Hüe S, Mention JJ, Monteiro RC, et al. A direct role for NKG2D/MICA interaction in villous atrophy during celiac disease. *Immunity* 2004;21:367-77.
- Hunt KA, McGovern DP, Kumar PJ, et al. A common CTLA-4 haplotype associated with coeliac disease. *Eur J Hum Genet* 2005;13:440-4.
- Hunt KA, Monsuur AJ, McArdie WL, et al. Lack of association of MYO9B genetic variants with coeliac disease in a British cohort. *Gut* 2006;55:969-72.
- Hällström O. Comparison of IgA-class reticulin and endomysium antibodies in coeliac disease and dermatitis herpetiformis. *Gut* 1989;30:1225-32.
- Högberg L, Falth-Magnusson K, Grodzinsky E, Stenhammar L. Familial prevalence of coeliac disease: a twenty-year follow-up study. *Scand J Gastroenterol* 2003;38:61-5.
- Ivarsson A, Hernell O, Stenlund H, Persson LA. Breast-feeding protects against celiac disease. *Am J Clin Nutr* 2002;75:914-21.

Janatuinen EK, Pikkarainen PH, Kempainen TA, et al. A comparison of diets with and without oats in adults with celiac disease. *N Engl J Med* 1995;333:1033-7.

Janatuinen EK, Kempainen TA, Julkunen RJ, et al. No harm from five-year ingestion of oats in coeliac disease. *Gut* 2002;50:332-5.

Järvinen TT, Collin P, Rasmussen M, et al. Villous tip intraepithelial lymphocytes as markers of early-stage coeliac disease. *Scand J Gastroenterol* 2004;39:428-33.

Järvinen TT, Kaukinen K, Laurila K, et al. Intraepithelial lymphocytes in celiac disease. *Am J Gastroenterol* 2003;98:1332-7.

Kagnoff MF, Paterson YJ, Kumar PJ, et al. Evidence for the role of a human intestinal adenovirus in the pathogenesis of coeliac disease. *Gut* 1987;28:995-1001.

Kagnoff M. Overview and pathogenesis of celiac disease. *Gastroenterology* 2005;128:S10-18.

Karell K, Korponay-Szabo I, Szalai Z, et al. Genetic dissection between coeliac disease and dermatitis herpetiformis in sib pairs. *Ann Hum Genet* 2002;66:387-92.

Karell K, Louka AS, Moodie SJ, et al. HLA types in celiac disease patients not carrying the DQA1*05-DQB1*02 (DQ2) heterodimer: results from the European Genetics Cluster on celiac disease. *Hum Immunol* 2003;64:469-77.

Kaukinen K, Partanen J, Mäki M, Collin P. HLA-DQ typing in the diagnosis of celiac disease. *Am J Gastroenterol* 2002a;97:695-9.

Kaukinen K, Sulkanen S, Mäki M, Collin P. IgA-class transglutaminase antibodies in evaluating the efficacy of gluten-free diet in coeliac disease. *Eur J Gastroenterol Hepatol* 2002b;14:311-5.

Kaukinen K, Peräaho M, Collin P, et al. Small-bowel mucosal transglutaminase 2 –specific IgA deposits in coeliac disease without villous atrophy: a prospective and randomized clinical study. *Scand J Gastroenterol* 2005;40:564-72.

Kaukinen K, Collin P, Laurila K, Kaartinen T, Partanen J, Mäki M. Resurrection of gliadin antibodies in coeliac disease. Deamidated gliadin peptide antibody test provides additional diagnostic benefit. *Scand J Gastroenterol* 2007;19;1-6 Epub ahead of print

Keuning JJ, Pena AS, van Leeuwen A, van Hooff JP, van Rood JJ. HLA-Dw3 associated with coeliac disease. *Lancet* 1976;1:506-8.

Kim CY, Quarsten H, Bergseng E, et al. Structural basis for HLA-DQ2-mediated presentation of gluten epitopes in celiac disease. *Proc Natl Acad Sci U S A* 2004; 101:4175-9.

King AL, Yiannakou JY, Brett PM, et al. A genome-wide family-based linkage study of coeliac disease. *Ann Hum Genet* 2000;64:479-90.

- King AL, Fraser JS, Moodie SJ, et al. Coeliac disease: follow-up linkage study provides further support for existence of a susceptibility locus on chromosome 11p11. *Ann Hum Genet* 2001;65:377-86.
- King AL, Moodie SJ, Fraser JS, et al. CTLA-4 / CD28 gene region is associated with genetic susceptibility to coeliac disease in UK families. *J Med Genet* 2002;39:51-4.
- King AL, Moodie SJ, Fraser JS, et al. Coeliac disease: investigation of proposed causal variants in the CTLA4 gene region. *Eur J Immunogenet* 2003;30:427-32.
- Kittles RA, Perola M, Peltonen L, et al. Dual origins of Finns revealed by Y chromosome haplotype variation. *Am J Hum Genet* 1998;62:1171-9.
- Koning F. Caught between a rock and a hard place. *Gastroenterology* 2005;129:1294-1301.
- Kruglyak L, Lander ES. Complete multipoint sib-pair analysis of qualitative and quantitative traits. *Am J Hum Genet* 1995;57:439-54.
- Kruglyak L, Daly MJ, Reeve-Daly MP, Lander ES. Parametric and nonparametric linkage analysis: a unified multipoint approach. *Am J Hum Genet* 1996;58:1347-63.
- Ladinsker B, Rossipal E, Pittschieler K. Endomysium antibodies in coeliac disease: an improved method. *Gut* 1994;35:776-8.
- Lander E, Kruglyak L. Genetic dissection of complex traits: guidelines for interpreting and reporting linkage results. *Nat Genet* 1995;11:241-7.
- Latiano A, Mora B, Bonamico M, et al. Analysis of candidate genes on chromosome 5q and 19p in celiac disease. *J Pediatr Gastroenterol Nutr* 2007;45:180-6.
- Lio D, Scola L, Forte GI, et al. TNF α , IFN γ and IL-10 gene polymorphisms in a sample of Sicilian patients with coeliac disease. *Dig Liver Dis* 2005;37:756-60.
- Liu J, Juo SH, Holopainen P, et al. Genomewide linkage analysis of celiac disease in Finnish families. *Am J Hum Genet* 2002;70:51-9.
- Lo W, Sano K, Lebwohl B, Diamond B, Green P. Changing presentation of adult celiac disease. *Dig Dis Sci* 2003;48:395-8.
- Logan RF, Rifkind EA, Turner ID, Ferguson A. Mortality in celiac disease. *Gastroenterology* 1989;97:265-71.
- Lohi S, Mustalahti K, Kaukinen K, et al. Increasing prevalence of coeliac disease over time. *Aliment Pharmacol Ther* 2007;26:1217-25.
- Lopez-Vazquez A, Rodrigo L, Fuentes D, et al. MHC class I chain related gene A (MICA) modulates the development of coeliac disease in patients with the high risk heterodimer DQA1*0501 / DQB1*0201. *Gut* 2002;50:336-40.

- Lopez-Vasquez A, Fuentes D, Rodrigo L, et al. MHC class I region plays a role in the development of diverse clinical forms of celiac disease in a Saharawi population. *Am J Gastroenterol* 2004;99:662-7.
- Louka AS, Stensby E, Ek J, Gudjonsdottir A, Ascher H, Sollid LM. Coeliac disease candidate genes: No association with functional polymorphisms in matrix metalloproteinase 1 and 3 gene promoters. *Scand J Gastroenterol* 2002a;37:931-935.
- Louka AS, Torinsson Naluai Å, D'Alfonso S, et al. The *IL12B* gene does not confer susceptibility to coeliac disease. *Tissue Antigens* 2002b;59:70-2.
- Louka AS, Sollid LM. HLA in coeliac disease: unravelling the complex genetics of a complex disorder. *Tissue Antigens* 2003;61:105-17.
- Lundin KE, Scott H, Hansen T, et al. Gliadin-specific, HLA-DQ(alpha1*0501, beta1*0201) restricted T cells isolated from the small intestinal mucosa of celiac disease patients. *J Exp Med* 1993;178:187-96.
- Lundin K, Scott H, Fausa O, Thorsby E, Sollid L. T cells from the small intestinal mucosa of a DR4, DQ7/DR4, DQ8 celiac disease patient preferentially recognise gliadin when presented by DQ8. *Hum Immunol* 1994;41:285-291.
- MacDonald WC, Dobbins WO, Rubin CE. Studies of the familial nature of celiac sprue using biopsy of the small intestine. *N Engl J Med* 1965;272:448-56.
- Maiuri L, Ciacci C, Auricchio S, Brown V, Quarantino S, Londei M. Interleukin 15 mediates epithelial changes in celiac disease. *Gastroenterology* 2000;119:996-1006.
- Maiuri L, Ciacci C, Vacca L, et al. IL-15 drives the specific migration of CD94+ and TCR- $\gamma\delta$ + intraepithelial lymphocytes in organ cultures of treated celiac patients. *Am J Gastroenterol* 2001;96:150-6.
- Maiuri L, Ciacci C, Ricciardelli I, et al. Association between innate response to gliadin and activation of pathogenic T cells in coeliac disease. *Lancet* 2003;362:30-7.
- Marietta E, Black K, Camilleri M, et al. A new model for dermatitis herpetiformis that uses HLA-DQ8 transgenic NOD mice. *J Clin Invest* 2004;114:1090-7.
- Marks J, Shuster S, Watson AJ. Small-bowel changes in dermatitis herpetiformis. *Lancet* 1966;2:1280-2.
- Marks J, Birkett D, Shuster S, Roberts DF. Small intestinal mucosal abnormalities in relatives of patients with dermatitis herpetiformis. *Gut* 1970;11:493-7.
- Marsh MN. Gluten, major histocompatibility complex, and the small intestine. A molecular and immunobiologic approach to the spectrum of gluten sensitivity ("celiac sprue"). *Gastroenterology* 1992;102:330-54.
- Martin-Pagola A, Perez de Nanclares G, Vitoria JC, et al. No association of CTLA4 gene with celiac disease in the Basque population. *J Pediatr Gastroenterol Nutr* 2003;37:142-5.

- McManus R, Moloney M, Borton M, et al. Association of celiac disease with microsatellite polymorphisms close to the tumor necrosis factor genes. *Hum Immunol* 1996;45:24-31.
- Mearin ML, Biemond I, Pena AS, et al. HLA-DR phenotypes in Spanish coeliac children: their contribution to the understanding of the genetics of the disease. *Gut* 1983;24:532-7.
- Meddeb-Garnaoui A, Zeliszewski D, Mougenot JF, et al. Reevaluation of the relative risk for susceptibility to celiac disease of HLA-DRB1, -DQA1, -DQB1, -DPB1, and TAP2 alleles in French population. *Hum Immunol* 1995;43:190-9.
- Mention J, Ahmed M, Begue B, et al. Interleukin 15: A key to disrupted intraepithelial lymphocyte homeostasis and lymphomagenesis in celiac disease. *Gastroenterology* 2003;125:730-45.
- Miller SA, Dykes DD, Polesky HF. A simple salting out procedure for extracting DNA from human nucleated cells. *Nucleic Acids Res* 1988;16:1215.
- Molberg Ø, McAdam SN, Körner R, et al. Tissue transglutaminase selectively modifies gliadin peptides that are recognized by gut-derived T cells in celiac disease. *Nat Med* 1998;4:713-7.
- Monsuur AJ, de Bakker PI, Alizadeh BZ, et al. Myosin IXB variant increases the risk of celiac disease and points toward a primary intestinal barrier defect. *Nat Genet* 2005;37:1341-4.
- Monteleone G, Pender SL, Wathen NC, MacDonald TT. Interferon-alpha drives T-cell mediated immunopathology in the intestine. *Eur J Immunol* 2001;31:2247-55.
- Moodie S, Norman P, King A, et al. Analysis of candidate genes on chromosome 19 in coeliac disease: an association study of the KIR and LILR gene clusters. *Journal of Immunogenetics* 2002;29:287-91.
- Mora B, Bonamico M, Indovina P, et al. CTLA-4 +49 A/G dimorphism in Italian patients with celiac disease. *Hum Immunol* 2003;64:297-301.
- Mora B, Bonamico M, Ferri M, et al. Association of the matrix metalloproteinase-3 (MMP-3) promoter polymorphism with celiac disease in male subjects. *Hum Immunol* 2005;66:716-20.
- Morris JA, Gardner MJ. Calculating confidence intervals for relative risks (odds ratios) and standardized ratios and rates. *Br Med J* 1988;296:1313-16.
- Mustalahti K, Holopainen P, Karell K, Mäki M, Partanen J. Genetic dissection between silent and clinically diagnosed symptomatic forms of coeliac disease in multiplex families. *Digest Liver Dis* 2002;34:842-5.
- Mylotte M, Egan-Mitchell B, Fottrell PF, McNicholl B, McCarthy CF. Family studies in coeliac disease. *Q J Med* 1974;43:359-69.

Mäki M, Holm K, Lipsanen V, et al. Serological markers and HLA genes among healthy first-degree relatives of patients with coeliac disease. *Lancet* 1991;338:1350-3.

Mäki M, Collin P. Coeliac disease. *Lancet* 1997;349:1755-9.

Mäki M, Mustalahti K, Kokkonen J, et al. Prevalence of celiac disease among children in Finland. *N Engl J Med* 2003;348:2517-24.

Naluai ÅT, Nilsson S, Samuelsson L, et al. The CTLA4/CD28 gene region on chromosome 2q33 confers susceptibility to celiac disease in a way possibly distinct from that of type 1 diabetes and other chronic inflammatory disorders. *Tissue Antigens* 2000;56:350-5.

Naluai ÅT, Nilsson S, Gudjonsdottir AH, et al. Genome-wide linkage analysis of Scandinavian affected sib-pairs supports presence of susceptibility loci for celiac disease on chromosomes 5 and 11. *Eur J Hum Genet* 2001;9:938-44.

Neuhausen SL, Feolo M, Farnham J, Book L, Zone JJ. Linkage analysis of HLA and candidate gene regions for celiac disease in a North American family-based study. *BMC Med Genet* 2001;2:12.

Neuhausen SL, Feolo M, Camp NJ, Farnham J, Book L, Zone JJ. Genome-wide linkage analysis for celiac disease in North American families. *Am J Med Genet* 2002;111:1-9.

Nilsen EM, Lundin KEA, Krajcl P, et al. Gluten specific, HLA-DQ restricted T cells from coeliac mucosa produce cytokines with Th1 or Th0 profile dominated by interferon gamma. *Gut* 1995;37:766-7.

Nistico L, Fagnani C, Coto I, et al. Concordance, disease progression, and heritability of coeliac disease in Italian twins. *Gut* 2006;55:803-8.

Not T, Horvath K, Hill ID, et al. Coeliac disease risk in USA: high prevalence of antiendomysium antibodies in healthy blood donors. *Scand J Gastroenterol* 1998;33:494-8.

Nunez C, Alecsandru D, Varade J, et al. Interleukin-10 haplotypes in celiac disease in the Spanish population. *BMC Med Genet* 2006a;31:7:32.

Nunez C, Marquez A, Varade J, et al. No evidence of association of the MYO9B polymorphisms with celiac disease in the Spanish population. *Tissue Antigens* 2006b;68:489-92.

Orita M, Iwahana H, Kanazawa H, Hayashi K, Sekiya T. Detection of polymorphisms of human DNA by gel electrophoresis as single-strand conformation polymorphisms. *Proc Natl Acad Sci USA* 1989;86:2766-70.

Partanen J, Milner C, Campbell R, Mäki M, Lipsanen V, Koskimies S. HLA-linked heat-shock protein 70 (HSP70-2) gene polymorphism and celiac disease. *Tissue Antigens* 1993;41:15-9.

Partanen J. Major histocompatibility complex and coeliac disease. In: Mäki M, Collin P, Visakorpi JK, editors. *Coeliac disease, Proceedings of the International Symposium on*

Coeliac disease. Tampere, Finland: Institute of Medical Technology, University of Tampere; 1997. pp 253-64.

Paulley JW. Observations on the aetiology of idiopathic steatorrhoea, jejunal and lymph node biopsies. *BMJ* 1954;2:1318-21.

Percopo S, Babron MC, Whalen M, et al. Saturation of the 5q31-q33 candidate region for coeliac disease. *Ann Hum Genet* 2003;67:265-8.

Petronzelli F, Bonamico M, Ferrante P, et al. Genetic contribution of the HLA region to the familial clustering of coeliac disease. *Ann Hum Genet* 1997;61:307-17.

Ploski R, Ek J, Thorsby E, Sollid LM. On the HLA-DQ(α 1*0501, β 1*0201)-associated susceptibility in celiac disease: A possible gene dosage effect of DQB1*0201. *Tissue antigens* 1993;41:173-7.

Ploski R, Ascher H, Sollid LM. HLA genotypes and the increased incidence of celiac disease in Sweden. *Scand J Gastroenterol* 1996;31:1092-7.

Polvi A, Eland C, Koskimies S, Mäki M, Partanen J. HLA DQ and DP in Finnish families with celiac disease. *Eur J Immunogenet* 1996;23:221-34.

Polvi A, Arranz E, Fernandez-Arquero M, et al. HLA-DQ2-negative celiac disease in Finland and Spain. *Hum Immunol* 1998a;59:169-75.

Polvi A, Mäki M, Collin P, Partanen J. TNF microsatellite alleles a2 and b3 are not primarily associated with celiac disease in the Finnish population. *Tissue Antigens* 1998b;51:553-5.

Popat S, Högberg L, McGuire S, et al. Germline mutations in TGM2 do not contribute to coeliac disease susceptibility in the Swedish population. *Eur J Gastroenterol Hepatol* 2001;13:1477-9.

Popat S, Bevan S, Braegger CP, et al. Genome screening of coeliac disease. *J Med Genet* 2002a;39:328-31.

Popat S, Hearle N, Bevan S, Högberg L, Stenhammar L, Houlston RS. Mutational analysis of CD28 in coeliac disease. *Scand J Gastroenterol* 2002b;37:536-9.

Popat S, Hearle N, Högberg L, et al. Variation in the CTLA4/CD28 gene region confers an increased risk of coeliac disease. *Ann Hum Genet* 2002c;66:125-137.

Popat S, Hearle N, Wixey J, et al. Analysis of the CTLA4 gene in Swedish coeliac disease patients. *Scand J Gastroenterol* 2002d;37:28-31.

Powis SH, Rosenberg WM, Hall M, et al. TAP1 and TAP2 polymorphism in coeliac disease. *Immunogenetics* 1993;38:345-50.

Ramos-Arroyo MA, Feijóo E, Sanchez-Valverde F, et al. Heat-shock protein 70-1 and HLA class II gene polymorphisms associated with celiac disease susceptibility in Navarra (Spain). *Hum Immunol* 2001;62:821-5.

- Reunala T, Salo OP, Tiililainen A, et al. Family studies in dermatitis herpetiformis. *Ann Clin Res* 1976;8:254-61.
- Reunala T, Blomqvist K, Tarpila S, Halme H, Kangas K. Gluten-free diet in dermatitis herpetiformis. Clinical response of skin lesions in 81 patients. *Br J Dermatol* 1977;97:473-80.
- Reunala T, Kosnai I, Karpati S, Kuitunen P, Torok E, Savilahti E. Dermatitis herpetiformis: jejunal findings and skin response to a gluten free diet. *Arch dis Child* 1984;59:517-22.
- Reunala T, Collin P, Holm K, et al. Tolerance to oats in dermatitis herpetiformis. *Gut* 1998;43:490-3.
- Rioux JD, Stone VA, Daly MJ, et al. Familial eosinophilia maps to the cytokine gene cluster on human chromosomal region 5q31-q33. *Am J Hum Genet* 1998;63:1086-94.
- Rioux JD, Silverberg MS, Daly MJ, et al. Genomewide search in Canadian families with inflammatory bowel disease reveals two novel susceptibility loci. *Am J Hum Genet* 2000;66:1863-70.
- Risch N. Assessing the role of HLA-linked and unlinked determinants of disease. *Am J Hum Genet* 1987;40:1-14.
- Risch N, Merikangas K. The future of genetic studies of complex disease. *Science* 1996;273:1516-17.
- Risch NJ. Searching for genetic determinants in the new millennium. *Nature* 2000;405:847-56.
- Rodriguez-Rodero S, Rodrigo L, Fdez-Morera JL, et al. MHC class I chain-related gene B promoter polymorphisms and celiac disease. *Hum Immunol* 2006;67:208-14.
- Roschmann E, Wienker TF, Gerok W, Volk BA. T-cell receptor variable genes and genetic susceptibility to celiac disease: an association and linkage study. *Gastroenterology* 1993;105(6):1790-6.
- Rostami K, Kerckhaert J, Tiemessen R, von Blomberg BM, Meijer JW, Mulder CJ. Sensitivity of antiendomysium and antigliadin antibodies in untreated celiac disease: disappointing in clinical practise. *Am J Gastroenterol* 1999;94:888-94.
- Rostami K, Mulder CJ, van Overbeek FM, et al. Should relatives of coeliacs with mild complaints undergo a small-bowel biopsy despite negative serology. *Eur J Gastroenterol Hepatol* 2000;12:51-5.
- Roy-Choudhury D, Cooke WT, Tan DT, Banwell JG, Smits BJ. Jejunal biopsy: criteria and significance. *Scand J Gastroenterol* 1966;1:57-74.
- Rueda B, Lopez-Nevot M, Pascual M, et al. Polymorphism of the inducible nitric oxide synthase gene in celiac disease. *Hum Immunol* 2002;63:1062-5.

- Rueda B, Pascual M, Lopez-Nevot M, et al. Association of MICA-A5.1 allele with susceptibility to celiac disease in a family study. *Am J Gastro* 2003;98:359-62.
- Rueda B, Martinez A, Lopez-Nevot MA, et al. A functional variant of IFN γ gene is associated with coeliac disease. *Genes Immunol* 2004;5:517-9.
- Ryan AW, Thornton JM, Brophy K, et al. Haplotype variation at the IBD5/SLC22A4 locus (5q31) in coeliac disease in the Irish population. *Tissue Antigens* 2004;64:195-8.
- Ryan AW, Thornton JM, Brophy K, et al. Chromosome 5q candidate genes in coeliac disease: genetic variation at IL4, IL5, IL9, IL13, IL17B and NR3C1. *Tissue Antigens* 2005;65:150-5.
- Sacchetti L, Sarrantonio C, Pastore L, et al. Rapid identification of HLA DQA1*0501, DQB1*0201 and DRB1*04 alleles in celiac disease by a PCR-based methodology. *Clin Chem* 1997;43:2204-6.
- Salmi TT, Collin P, Järvinen O, et al. Immunoglobulin A autoantibodies against transglutaminase 2 in the small intestinal mucosa predict forthcoming coeliac disease. *Aliment Pharmacol Ther* 2006a;24:541-52.
- Salmi TT, Collin P, Korponay-Szabo IR, et al. Endomysial antibody-negative coeliac disease: clinical characteristics and intestinal autoantibody deposits. *Gut* 2006b;55:1746-53.
- Santin I, Castellanos-Rubio A, Perez de Nanclares G, Vitoria JC, Castano L, Bilbao JR. Association of KIR2DL5B gene with celiac disease supports the susceptibility locus on 19q13.4. *Genes Immun* 2007;8:171-6.
- Sategna-Guidetti C, Pulitano R, Grosso S, Ferfaglia G. Serum IgA antiendomysium antibody titers as a marker of intestinal involvement and diet compliance in adult celiac sprue. *J Clin Gastroenterol* 1993;17:123-127.
- Savilahti E, Viander M, Perkkiö M, Vainio E, Kalimo K, Reunala T. IgA antigliadin antibodies: a marker of mucosal damage in childhood coeliac disease. *Lancet* 1983;1:320-2.
- Schuppan D. Current concepts of celiac disease pathogenesis. *Gastroenterology* 2000;119:234-42.
- Seegers D, Borm ME, van Belzen, et al. IL12B and IRF1 gene polymorphisms and susceptibility to coeliac disease. *Eur J Immunogenet* 2003;30:421-5.
- Shan L, Molberg Ø, Parrot I, et al. Structural basis for gluten intolerance in celiac sprue. *Science* 2002;297:2275-79.
- Shih MC, Whittemore AS. Allele-sharing among affected relatives: non-parametric methods for identifying genes. *Stat Methods Med Res* 2001;10:27-55.
- Shiner M. Small intestinal biopsies by the oral route. *J Mt Sinai Hosp* 1957;24:273-7.
- Shipman RT, Williams AL, Kay R, Townley RRW. A family study of coeliac disease. *Aust NZ J Med* 1975;5:250-5.

Sollid LM, Markussen G, Ek V, Gjerde HG, Vartdal F, Thorsby E. Evidence for a primary association of coeliac disease to a particular HLA-DQ α - β heterodimer. *J Exp Med* 1989;169:345-50.

Sollid L, Thorsby E. The primary association of coeliac disease to a given HLA-DQ α/β heterodimer explains the divergent HLA-DR associations observed in various Caucasian populations. *Tissue Antigens* 1990;36:136-7.

Sollid LM, Thorsby E. HLA susceptibility genes in coeliac disease: Genetic mapping, and role in pathogenesis. *Gastroenterology* 1993;105:910-22.

Sollid LM, Khosla C. Future therapeutic options for coeliac disease. *Nat Clin Pract Gastroenterol Hepatol* 2005a;2:140-7.

Sollid LM, Lie BA. Coeliac disease genetics: Current concepts and practical applications. *Clin Gastroenterol Hepatol* 2005b;3:843-51.

Spielman RS, Ewens WJ. The TDT and other family-based tests for linkage disequilibrium and association. *Am J Hum Genet* 1996;59:983-9.

Spurkland A, Sollid LM, Rønningen KS, et al. Susceptibility to develop coeliac disease is primarily associated with HLA-DQ alleles. *Hum Immunol* 1990;29:157-65.

Spurkland A, Sollid LM, Polanco I, Vartdal F, Thorsby E. HLA-DR and -DQ genotypes of coeliac disease patients serologically typed to be non-DR3 or non-DR5/7. *Hum Immunol* 1992;35:188-92.

Spurkland A, Ingvarsson G, Falk ES, Knutsen I, Sollid LM, Thorsby E. Dermatitis herpetiformis and coeliac disease are both primarily associated with the HLA-DQ(alpha 1*0501, beta 1*02) or the HLA-DQ (alpha 1*03, beta 1*0302) heterodimers. *Tissue Antigens* 1997;49:29-34

Stene LC, Honeyman MC, Hoffenberg EJ, et al. Rotavirus infection frequency and risk of coeliac disease autoimmunity in early childhood: a longitudinal study. *Am J Gastroenterol* 2006;101:2333-40.

Stenhammar L, Brandt Å, Wågermark J. A family study of coeliac disease. *Acta Paediatr Scand* 1982;71:625-8.

Stokes PL, Asquith P, Holmes GKT, Macintosh P, Cooke WT. Histocompatibility antigens associated with adult coeliac disease. *Lancet* 1972;2:162-4.

Stokes PL, Ferguson R, Holmes GKT, Cooke WT. Familial aspects of coeliac disease. *Q J Med* 1976;45:567-82.

Sulkanen S, Collin P, Laurila K, Mäki M. IgA- ja IgG-class antihuman umbilical cord antibody tests in adult coeliac disease. *Scand J Gastroenterol* 1998a;33:251-4.

- Sulkanen S, Halttunen T, Laurila K, et al. Tissue transglutaminase autoantibody enzyme-linked immunosorbent assay in detecting celiac disease. *Gastroenterology* 1998b;115:1322-1328.
- Susi M, Holopainen P, Mustalahti K, Mäki M, Partanen J. Candidate gene region 15q26 and genetic susceptibility to coeliac disease in Finnish families. *Scand J Gastroenterol* 2001;36:372-4.
- Thurley CA, Kwan WC, Freeman HJ, Gilks CB. T cell receptor gene expression and genotypes in celiac disease. *Pathobiology* 1994;62:311-8.
- Tighe MR, Hall MA, Barbado M, et al. HLA-class II alleles associated with coeliac disease in a Southern European population. *Tissue Antigens* 1992;40:90-7.
- Tursi A, Brandimarte G, Giorgetti G, Gigliobianco A, Lombardi D, Gasbarrini G. Low prevalence of antigliadin and anti-endomysium antibodies in subclinical/silent celiac disease. *Am J Gastroenterol* 2001;96:1507-10.
- Vader W, Kooy Y, van Veelen P, et al. The gluten response in children with celiac disease is directed toward multiple gliadin and glutenin peptides. *Gastroenterology* 2002;122:1729-37.
- Vader W, Stepniak D, Kooy Y, et al. The HLA-DQ2 gene dose effect in celiac disease is directly related to the magnitude and breadth of gluten-specific T cell responses. *Proc Natl Acad Sci USA* 2003;100:12390-5.
- van Belzen MJ, Mulder JJ, Pearson PL, Houwen RHJ, Wijmenga C. The tissue transglutaminase gene is not a primary factor predisposing to celiac disease. *Am J Gastroenterol* 2001;96:3337-40.
- van Belzen MJ, Meijer JWR, Sandkuijl LA, et al. A major non-HLA locus in celiac disease maps to chromosome 19. *Gastroenterology* 2003;125:1032-41.
- van Belzen MJ, Mulder CJ, Zhernakova A, Pearson PL, Houwen RH, Wijmenga C. CTLA4 +49 A/G and CT60 polymorphisms in Dutch coeliac disease patients. *Eur J Hum Genet* 2004a;12:782-5.
- van Belzen MJ, Vrolijk MM, Meijer JW, et al. A genomewide screen in a four-generation Dutch family with celiac disease: evidence for linkage to chromosomes 6 and 9. *Am J Gastroenterol* 2004b;99:466-71.
- van der Meer JB. Granular deposits of immunoglobulins in the skin of patients with dermatitis herpetiformis. An immunofluorescent study. *Br J Dermatol* 1969;81:493-503.
- van de Wal Y, Kooy Y, van Veelen P, et al. Selective deamidation by tissue transglutaminase strongly enhances gliadin-specific T cell reactivity. *J Immunol* 1998;161:1585-8.
- van Heel DA, West J. Recent advances in coeliac disease. *Gut* 2006;55:1037-46.
- van Heel DA, Franke L, Hunt KA, et al. A genome-wide association study for celiac disease identifies risk variants in the region harboring *IL2* and *IL21*. *Nat Genet* 2007;39:827-9.

Vazquez H, Smecuol E, Flores D, et al. Relation between cigarette smoking and celiac disease: evidence from a case-control study. *Am J Gastroenterol* 2001;96:260-1.

Viljamaa M, Collin P, Huhtala H, Sievänen H, Mäki M, Kaukinen K. Is coeliac disease screening in risk groups justified? A fourteen-year follow-up with special focus on compliance and quality of life. *Aliment Pharmacol Ther* 2005;22:317-24.

Viljamaa M, Kaukinen K, Pukkala E, Hervonen K, Reunala T, Collin P. Malignancies and mortality in patients with coeliac disease and dermatitis herpetiformis: 30-year population based study. *Dig Liver Dis* 2006;38:374-80.

Volta U, Molinaro N, de Franceschi L, Fratangelo D, Bianchi FB. IgA anti-endomysial antibodies on human umbilical cord tissue for celiac disease screening. Save both money and monkeys. *Dig Dis Sci* 1995;40:1902-5.

Walker-Smith JA, Guandalini S, Schmitz J, Shmerling DH, Visakorpi JK. Revised criteria for diagnosis of coeliac disease. *Arch Dis Child* 1990;65:909-11.

Wapenaar MC, van Belzen MJ, Fransen JH, et al. The interferon gamma gene in celiac disease: augmented expression correlates with tissue damage but no evidence for genetic susceptibility. *J Autoimmun* 2004;23:183-90.

West J, Logan RF, Hill PG, et al. Seroprevalence, correlates, and characteristics of undetected coeliac disease in England. *Gut* 2003;52:960-5.

WMA. World Medical Association of Helsinki: Ethical principles for medical research involving human subjects. *J Postgrad Med* 2002;48:206-8.

Woolley N, Holopainen P, Bourgain C, et al. CD80 (B7-1) and CD86 (B7-2) genes and genetic susceptibility to coeliac disease. *Eur J Immunogenetics* 2002a;29:331-333.

Woolley N, Holopainen P, Ollikainen V, et al. A new locus for coeliac disease mapped to chromosome 15 in a population isolate. *Hum Genet* 2002b;111:40-45.

Woolley N, Mustalahti K, Mäki M, Partanen J. Cytokine gene polymorphisms and genetic association with coeliac disease in the Finnish population. *Scand J Immunol* 2005;61:51-6.

Yiannakou JY, Brett PM, Morris MA, et al. Family linkage study of the T-cell receptor genes in coeliac disease. *Ital J Gastroenterol Hepatol* 1999;31:198-201.

Zanoni G, Navone R, Lunardi C, et al. In celiac disease, a subset of autoantibodies against transglutaminase binds toll-like receptor 4 and induces activation of monocytes. *PLoS Med* 2006;3:e358.

Zhernakova A, Eerligh P, Barrera P, et al. CTLA4 is differentially associated with autoimmune diseases in the Dutch population. *Hum Genet* 2005;118:58-66.

Zhong F, McCombs CC, Olson JM, et al. An autosomal screen for genes that predispose to celiac disease in the Western counties of Ireland. *Nat Genet* 1996;14:329-33.

Zone JJ. Skin manifestations of celiac disease. *Gastroenterology* 2005;128:S87-91.

Zubillaga P, Vidales M, Zubillaga I, Ormaechea V, Garcia-Urkia N, Vitoria J. HLA-DQA1 and HLA-DQB1 genetic markers and clinical presentation in celiac disease. *J Pediatr Gastroenterol Nutr* 2002;34:548-54.

ORIGINAL PUBLICATIONS I-IV

Kuopio University Publications D. Medical Sciences

- D 400. Vasara, Anna.** Autologous chondrocyte transplantation: Properties of the repair tissue in humans and in animal models.
2007. 92 p. Acad. Diss.
- D 401. Andrulionyte, Laura.** Transcription factors as candidate genes for type 2 diabetes: studies on peroxisome proliferator-activated receptors, hepatic nuclear factor 4 α and PPAR γ coactivator 1 α .
2007. 112 p. Acad. Diss.
- D 402. Raatikainen, Kaisa.** Health behavioural and social risks in obstetrics: effect on pregnancy outcome.
2007. 100 p. Acad. Diss.
- D 403. Kinnunen, Tuure.** The role of T cell recognition in the immune response against lipocalin allergens: prospects for immunotherapy.
2007. 76 p. Acad. Diss.
- D 404. Gratz, Silvia.** Aflatoxin binding by probiotics : experimental studies on intestinal aflatoxin transport, metabolism and toxicity.
2007. 85 p. Acad. Diss.
- D 405. Ming, Zhiyong.** Upper limb musculoskeletal disorders with special reference to sympathetic nerve functions and tactile sensation.
2007. 91 p. Acad. Diss.
- D 406. Timonen, Leena.** Group-based exercise training in mobility impaired older women.
2007. 91 p. Acad. Diss.
- D 407. Mättö, Mikko.** B cell receptor signaling in human B cells.
2007. 74 p. Acad. Diss.
- D 408. Polychronaki, Nektaria.** Biomarkers of aflatoxin exposure and a dietary intervention: studies in infants and children from Egypt and Guinea and young adults from China.
2007. 114 p. Acad. Diss.
- D 409. Mursu, Jaakko.** The role of polyphenols in cardiovascular diseases.
2007. 88 p. Acad. Diss.
- D 410. Wlodkovic, Donald.** Selective targeting of apoptotic pathways in follicular lymphoma cells.
2007. 97 p. Acad. Diss.
- D 411. Skommer, Joanna.** Novel approaches to induce apoptosis in human follicular lymphoma cell lines - preclinical assessment.
2007. 80 p. Acad. Diss.
- D 412. Kempinen, Kaarina.** Early maternal sensitivity: continuity and related risk factors.
2007. 80 p. Acad. Diss.
- D 413. Sahlman, Janne.** Chondrodysplasias Caused by Defects in the Col2a1 Gene.
2007. 86 p. Acad. Diss.
- D 414. Pitkänen, Leena.** Retinal pigment epithelium as a barrier in drug permeation and as a target of non-viral gene delivery.
2007. 75 p. Acad. Diss.
- D 415. Suhonen, Kirsi.** Prognostic Role of Cell Adhesion Factors and Angiogenesis in Epithelial Ovarian Cancer.
2007. 123 p. Acad. Diss.